

# Single Phase Hybrid Inverter MHSI-01LP1 (5/6/8/10K)

# User Manual

# Contents

Cautions .....	1
<b>1 General Introduction .....</b>	<b>2</b>
1.1 Brief Description .....	2
1.2 Product Features .....	2
1.3 Product Appearance Introduction .....	3
1.4 Product Size .....	5
1.5 System structure .....	6
1.6 Inverter parameter .....	6
<b>2 Installation Instructions .....</b>	<b>7</b>
2.1 Installation preparation .....	7
2.1.1 Installation Notes Reiterated .....	7
2.1.2 Installation environment, space requirements .....	7
2.1.3 Installation tool preparation .....	8
2.1.4 Inspection of out-of-box accessories .....	8
2.2 Introduction of equipment terminal .....	11
2.3 Wall mount .....	13
2.4 Battery wiring work .....	14
2.4.1 Battery Power Cable Wiring .....	14
2.4.2 Battery communication cable connection .....	16
2.5 Power grid, load, GEN wiring .....	16
2.6 Photovoltaic wiring .....	17
2.7 CT wiring .....	19
2.8 Meter connection .....	20
2.9 Ground connection .....	21
2.10 WIFI connection .....	21
2.11 Stand-alone operation system diagram .....	21
<b>3 Display and setup .....</b>	<b>22</b>
3.1 Run data display instructions .....	22
3.1.1 Photovoltaic data .....	24
3.1.2 Battery data .....	26
3.1.3 Inverter data .....	27
3.1.4 Grid data .....	28
3.1.5 Load data .....	29
3.2 Run parameter setting .....	30
3.2.1 Battery parameter setting .....	30
3.2.2 Grid parameter setting .....	33
3.2.3 GEN port function settings .....	34
3.2.4 CT transformation ratio setting .....	36

3.2.5 Safety setting .....	36
3.2.6 Operating Mode Settings .....	38
3.2.7 System Setup .....	39
3.3 Events Display .....	39
3.4 Device Info .....	39
<b>4 Operation and maintenance .....</b>	<b>41</b>
4.1 Trial run .....	41
4.1 Stand-alone operation and logic description .....	41
4.1.1 Enter working mode to set path .....	42
4.1.2 .Sell First .....	42
4.1.3 Zero Ex To Grid Port .....	43
4.1.4 Zero Ex To CT .....	43
4.1.5 Time curve mode .....	43
4.2 Parallel operation and logical explanation .....	44
4.2.1 Set entry path description .....	45
4.2.2 Parallel operation logic .....	45
4.2.3 Parallel system wiring diagram .....	45
4.3 Example of five parallel inverter .....	48
4.3.1 Grid and load connection .....	48
4.3.2 Parallel cable connection and check .....	48
4.3.3 ON-Grid startup parallel .....	50
4.3.4 Off-grid startup parallel .....	50
4.3.4 Shut down the Inverter .....	51
4.4 Fault alarm and handling .....	51
4.5 Product routine maintenance suggestions .....	55
4.5.1 Routine inspection .....	55
4.5.2 Monthly inspection .....	55
4.5.3 Quarterly inspection .....	56
<b>5 Transportation and storage .....</b>	<b>57</b>
5.1 Product Shipping Requirements .....	57
5.1.1 Logistics .....	57
5.1.2 Unloading and handling .....	57
5.2 Product storage environment requirements .....	57
<b>6 Legal Notices .....</b>	<b>58</b>
<b>7 Attachments .....</b>	<b>59</b>
Network port definition description .....	59
CT size and model .....	60
Hybrid Inverter data .....	61

# Cautions

- Before using this product, please read the instruction manual carefully.
- Non-professionals should not disassemble the machine, wrong reassembly may cause electric shock or fire. If you need maintenance or repair, please contact the after-sales service center.
- For your safety, please disconnect all power and cables of this equipment before maintenance or cleaning.
- Note: Non-professionals are not allowed to install this device and battery.
- In order to ensure the best working condition of this device, please select the appropriate cable size correctly.
- Please try to avoid using metal tools near the battery. If you must use it, please be careful. Dropping the tool may cause sparks or short circuits on the battery or other electrical components, or even cause an explosion.
- When disconnecting the AC or DC terminals, please strictly follow the installation steps. For details, please refer to the "Installation" section of this manual.
- Grounding Instructions - This equipment should be connected to a permanently grounded wiring system. Be sure to follow local requirements and regulations when installing this equipment.

Do not short-circuit the AC output and DC input, and do not connect the mains when short-circuited.

# 1 General Introduction

This manual mainly introduces product information, functional operation, equipment installation and maintenance guidelines. This brochure does not cover all information related to photovoltaics.

## 1.1 Brief Description

The hybrid inverter intergrate PV power generation and energy storage, it fouse on provide high power generation and stable power supply. It designed according to market requirements of residential and industrial hybrid system. It not only can be used in self-consumprion hybrd system, but also be use for battery back system. To meet different condition, it can work at on-grid and off-grid condition. You can parallel more inverters to meet industrial system require ments.

## 1.2 Product Features

The hybrid inverter adopts advanced digital control technology, which optimizes the control performance and improves the reliability of the system. The inverter features as below

- Intelligent management system and a variety of working modes to meet different customer needs.
- Strong scalability. Support different power inverters parallel, support a maximum of 20 inverters parallel operation.
- Supports on/off-grid work mode switching. Strong overload capability. 110% overload can run for 2 hours. 100% unbalanced load is supported
- Installed a large touch screen color. It also supports computer, mobile phone or Internet remote monitoring, operation and upgrade. The operating information such as inverter and battery mode can be set on the touch screen.
- Protection class IP65. Light weight, small size. Easy to install.
- Two MPPT, flexible module configuration.
- Independent AC input interface for diesel generator. Support storage of energy from diesel generators.
- With intelligent load or AC coupling device interface. Suitable for a variety of scenarios.
- Photovoltaic arc arc detection optional. With photovoltaic input lightning protection.
- With reactive power regulation function.
- Supports overtemperature, overcurrent, and short circuit protection. Supports anti-island protection and other protection functions. Ensure the safe, stable and reliable operation of the system.

### 1.3 Product Appearance Introduction

The appearance of this product and its various descriptions are shown in Figure 1.1 and Table 1.1 below.

Table 1.1 Description of product componets

Number	Definition	Description
1	Indicator light	
2	LCDdisplay screen	
3	Function buttons	
4	Battery forced start button	
5	PV input knob	
6	Battery input interface	
7	ModBUS interface	
8	Meter-485 interface	
9	Parallel communication interface	
10	CT and other port	
11	BMS interface	
12	Grid switch	
13	Load interface	
14	Gen interface	
15	PV input interface	With 2 MPPT
16	WIFI interface	

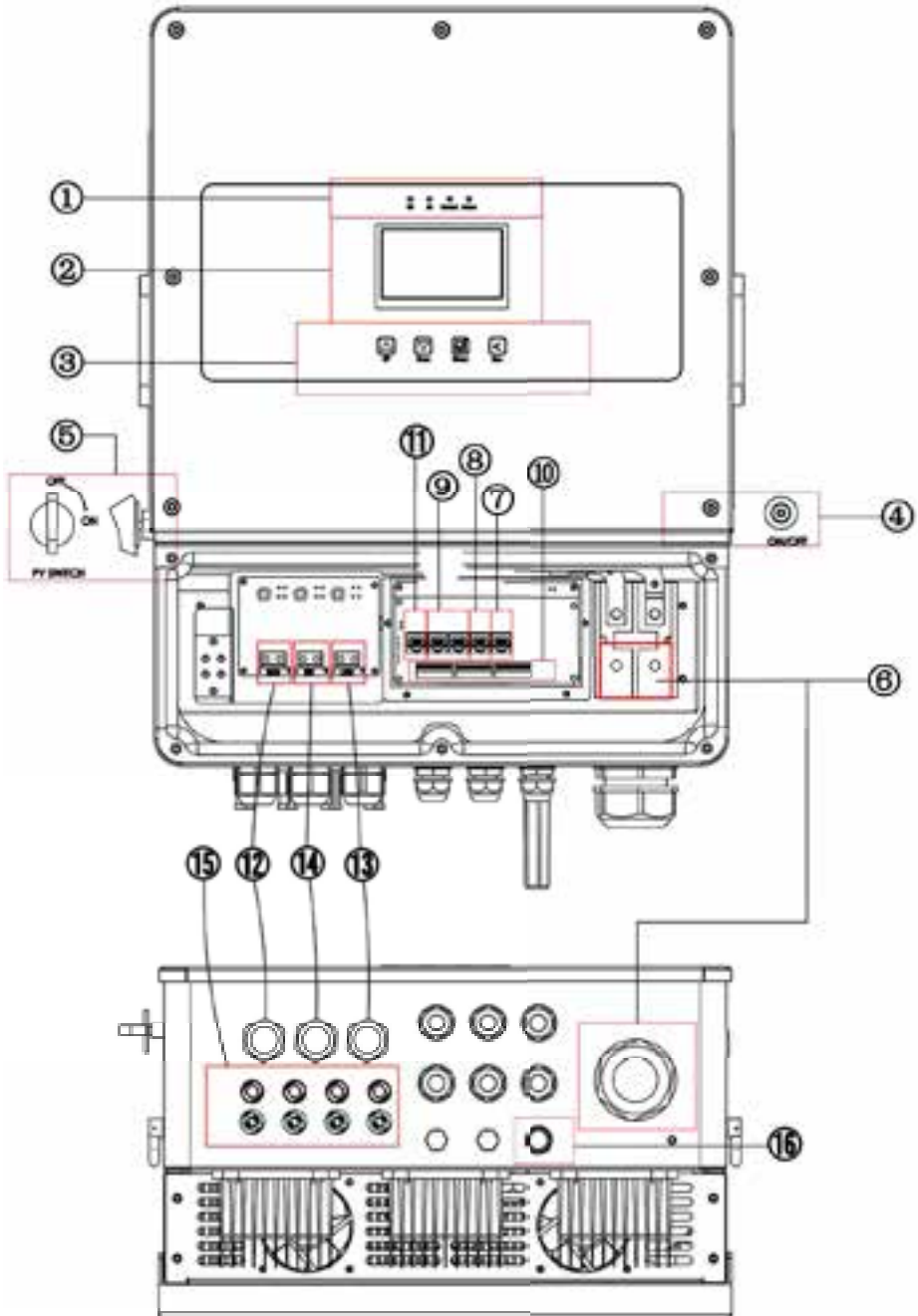
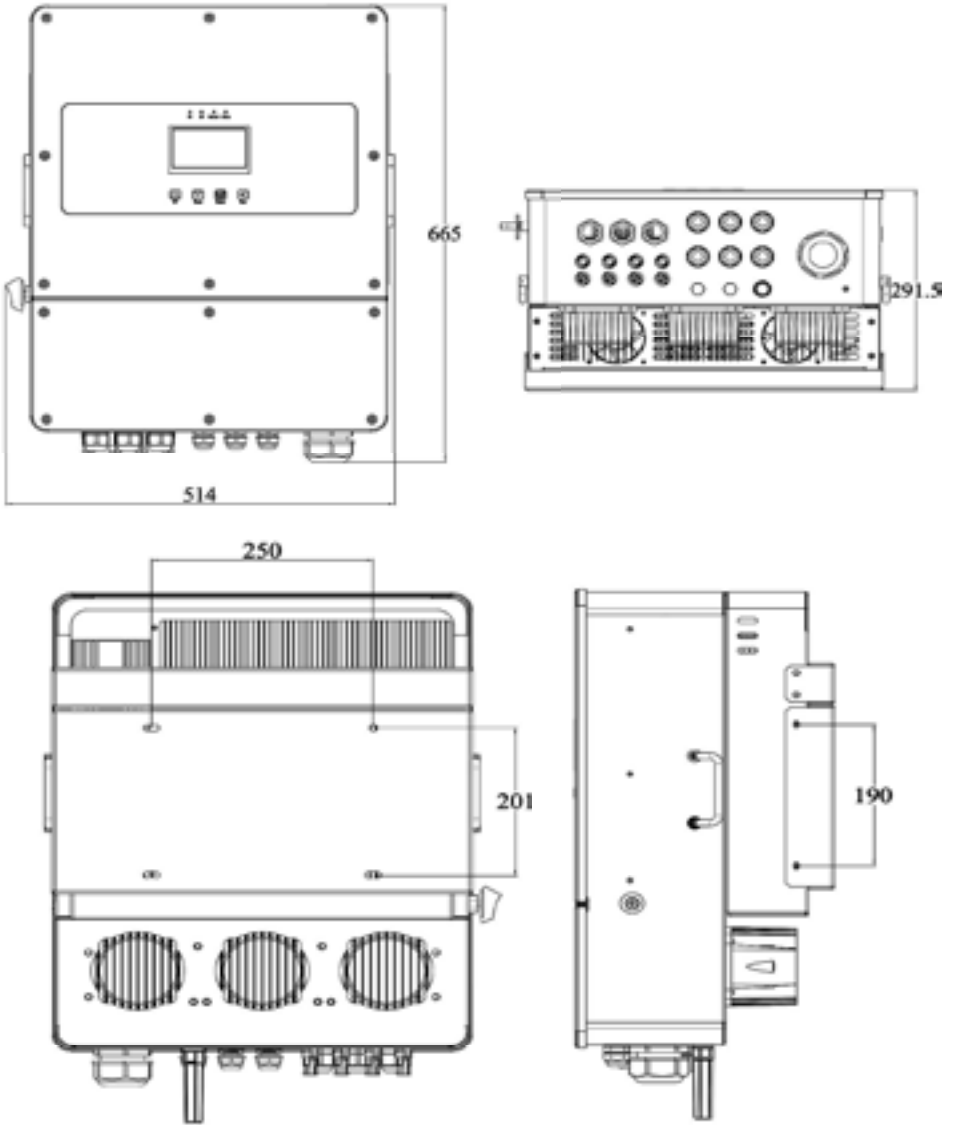

Figure 1.1 Overview of Hybrid Inverter Appearance

## 1.4 Product Size



- Size W\*H\*D mm : 514x665x292.
- Weight kg : 45 .



## 1.5 System structure

As shown in Figure 1.2, it shows the basic application of the solar-storage integrated machine, and its complete operating system also includes: diesel generators, power grids, and photovoltaic modules. Depending on your requirements, other possible system architectures are available from your system integrator. The device can power a variety of appliances in a home or office environment, including motor-type appliances such as refrigerators and air conditioners

# ON/OFF GRID SOLAR HYBRID HOME SYSTEM

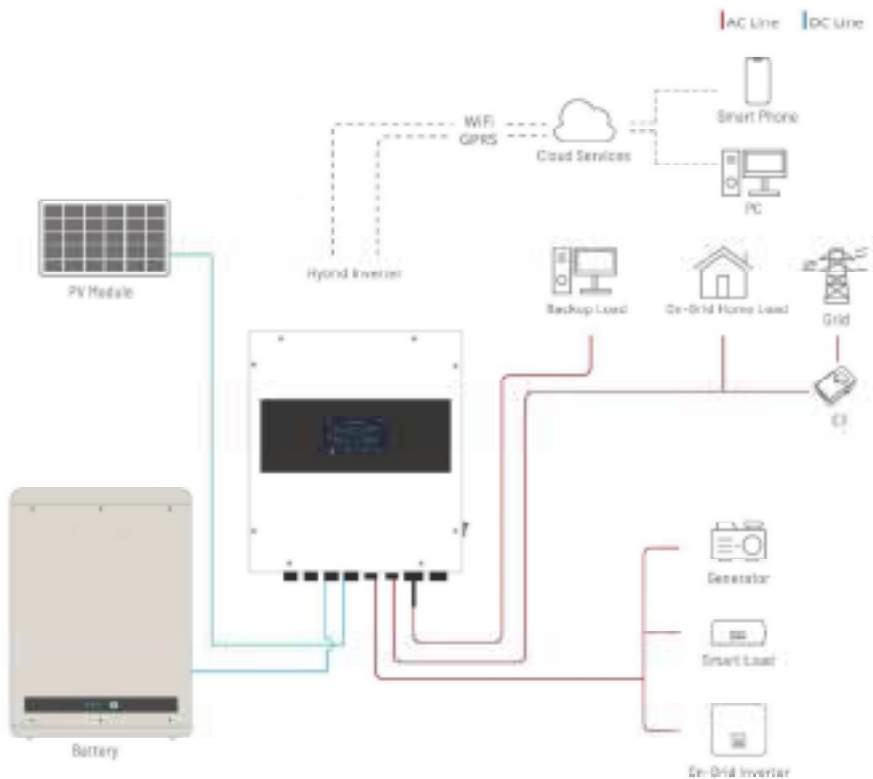

Figure 1.2 Complete operation system of hybrid inverter

## 1.6 Inverter parameter

The detailed technical specifications of this equipment are detailed in the annex.

## 2 Installation Instructions

### 2.1 Installation preparation

#### 2.1.1 Installation Notes Reiterated

This device is designed for outdoor use IP65 , please ensure that the installation site meets the following conditions:

- out of direct sunlight.
- Not in areas where highly flammable materials are stored.
- Not in potentially explosive area.
- Do not expose directly to cold air.
- Keep away from TV antennas or antenna cables.

#### 2.1.2 Installation environment, space requirements

To ensure the normal operation of the hybrid inverter, please install the equipment in a controlled environment. At the same time, in order to avoid overheating of the energy storage converter module, please keep the storage device ventilated smoothly. The ventilation holes and fans must not be blocked by sundries. The installation site must meet the following conditions:

- 1 Close to the power supply, easy to distribute power.
- 2 Clean and dust-free environment.
- 3 The altitude does not exceed 3000m, if it exceeds, the relevant national standards need to be installed for derating.
- 4 The ambient temperature is  $-45 \sim 60^{\circ}\text{C}$ .
- 5 No corrosive, explosive and insulating gas and conductive dust, and keep away from heat sources.
- 6 No vibration and bumps, and the vertical inclination does not exceed 5%.
- 7 If the energy storage converter module operates in an air-conditioned environment around  $20^{\circ}\text{C}$  , it will improve reliability and prolong service life.

Consider the following points before choosing an installation location:

- For installation, please choose a vertical wall with strong load-bearing capacity, suitable for installation.
- On concrete or other non-flammable surfaces, install as shown in figure 1.3 below.
- Install this inverter at the line of sight level so that the LCD display can be read at any time.
- The ambient temperature should be between  $-45^{\circ}\text{C}$  and  $60^{\circ}\text{C}$  to ensure the best operation.
- Please install the equipment in a position with sufficient distance reserved, as shown in figure

2.1 to ensure sufficient heat dissipation and enough space to remove the stitches. For proper air circulation to dissipate heat, leave a gap of approximately 1000mm. Lateral 500mm, upper and lower 500mm, and anterior outflow of 1000mm.

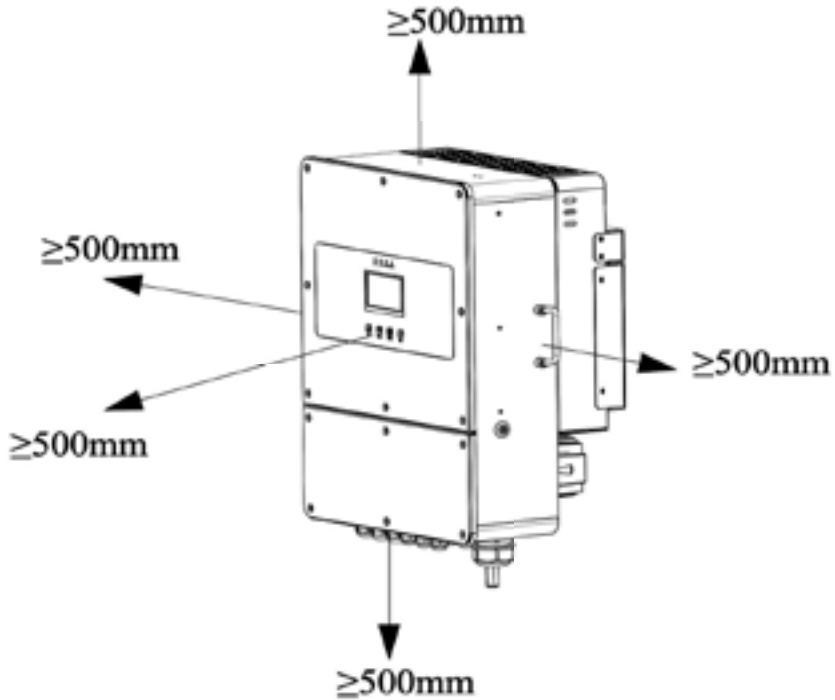

Figure 2.1 recommended reserved distance around the equipment

### 2.1.3 Installation tool preparation

Phillips screwdriver specification: PH2, moderate length , diameter 5.5mm, 10mm, 13mm wrench or sleeve for M3, M6, M8 outer hexagon screws

### 2.1.4 Inspection of out-of-box accessories

Please check the equipment before installation. Please make sure that there is no damage to the packing. The package you receive should include the items in Table 2.1, as shown in figure 2.2 below.

Table 2.1 Product list details

Serial number	Item name/specification	Quantity	Remarks
1	Inverter this equipment	1	
2	User manual	1	Place it in the box
3	Shipment inspection report	1	
4	V07.00001.05 mounting bracket	1	
5	Hardware/screws/stainless steel built-in expansion screws hexagonal internal expansion bolts, M8*80	4	For securing the chassis
6	Allen stainless steel combination screws M6X16	4	For fixing small enclosures
7	Allen stainless steel combination screws M4X12	4	For fixing large enclosures
8	Wi-Fi Stick	1	Shipped with the shipment
9	Current sensor/CTSA016 100A/50mA	1	
10	Communication cable/Cat5e super 5 category 5 finished network cable 2 meters long	1	
11	CAN parallel wire/twisted pair shielded wire 2m	1	For parallel operation
12	PV inputconnector/MC4/line end female end/H4CFD2TMS/nut pin	4	5K 6K only 2
13	PV input connector/MC4/line-end male/H4CMD2TMS/nut with pin	4	5K 6K only 2
14	Smart Meter/SMD230	1	Optional
15	Battery Temperature Sensor/NTC Temperature Sensor B3950 10K thermistor, stainless steel waterproof probe 3 meters long	1	Optional
16	Certificate	1	
17	Warranty card	1	
18	PE transparent bag/transparent ziplock bag 160*320	3	Assembly accessories accessories, etc
19	Excipients / environmental protection / desiccant / 5g / pack	3	Packed in a box
20	L-shaped 3mm hexagon wrench	1	Optional











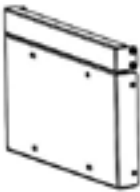

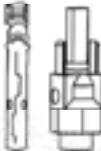
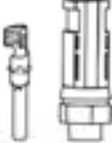
 <p>Hybrid Inverter X1</p>	<p>User manual</p> <p>User manual X1</p>	<p>Shipment inspection report</p> <p>Shipment inspection report X1</p>	<p>Certificate of approval</p> <p>Certificate of approval X1</p>
<p>Warranty Card</p> <p>Warranty Card X1</p>	 <p>Wallmounting bracket X1</p>	 <p>Stainless steel anti-collision bolt M8X80 X4</p>	 <p>Allen stainless steel combination screws M6X16 X4</p>
 <p>PV input connector/MC4 line end male/114CMD2TMS/ with pin nut X4 (5, 6K X2)</p>	 <p>PV input connector/MC4 line end female/114CFD2TMS/ with pin nut X4 (5, 6K X2)</p>	 <p>Wifi-stick X1</p>	 <p>Allen stainless steel combination screws M4X12 X4</p>
 <p>Communication cable X 2m</p>	 <p>Can parallel line X 2m</p>	 <p>NTC Battery Temperature Sensor X1</p>	 <p>Desiccant *3</p>
 <p>(Optional) Smart Meter X1</p>	 <p>Self-sealing bags *5</p>	 <p>(Optional) L-shaped 3mm hexagon wrench X1</p>	 <p>Sensor Clamp X1</p>

Figure 2.2 Product list details

## 2.2 Introduction of equipment terminal

The function of the keys near the LCD is shown in figure 2.3. The function of the connection socket and through hole at the bottom of the equipment is shown in figure 2.4. the function of the button and knob on the side of the equipment is shown in figure 2.5. the internal and external interface board of the equipment is shown in figure 2.6. the corresponding terminal function is shown in Table 2.2.

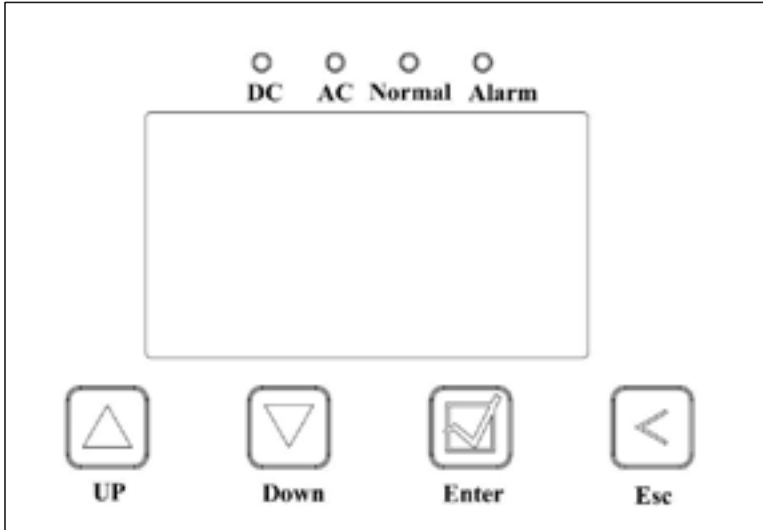

Figure 2.3 key definition near LCD

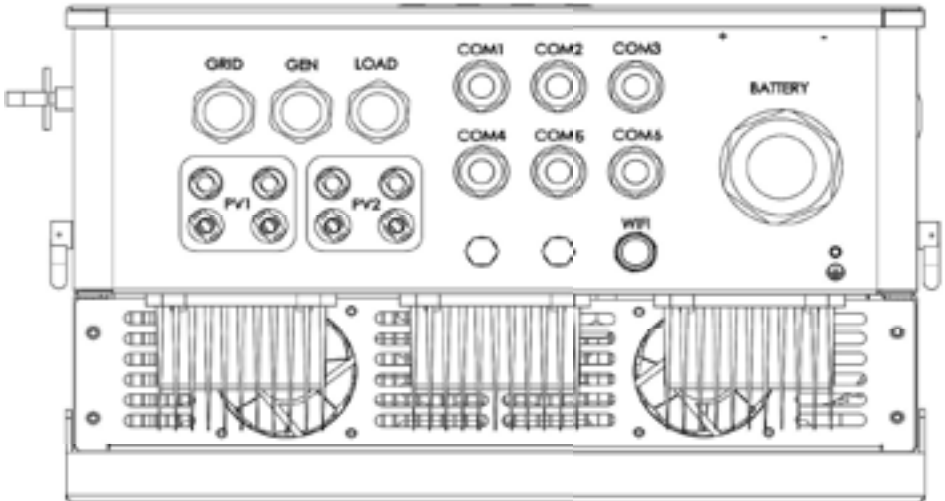

Figure 2.4 definition of socket terminal at the bottom of the device

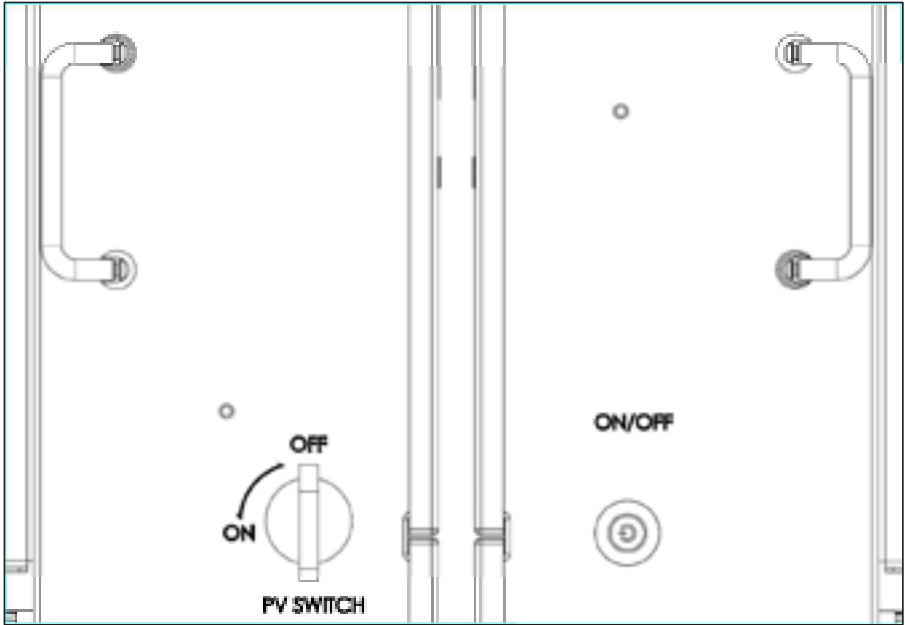

Figure 2.5 definition of side buttons and knobs on the device

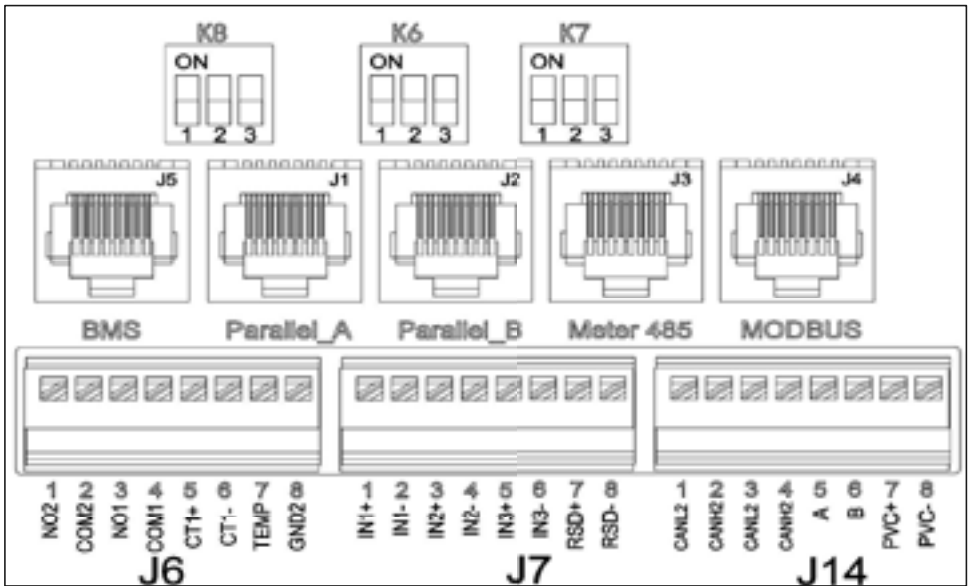

Fig. 2.6 schematic diagram of internal and external interface board of equipment

Table 2.2 definition of device internal external interface board

MARK	J6-1	J6-2	J6-3	J6-4	J6-5	J6-6	J6-7	J6-8
Definition	NO2	COM2	NO1	COM1	CT1+	CT1-	BAT-TEMP	ISOGND2
Function	Gen adjustment control		Gen start control		External A-phase CT1 sampling input		Battery temperature sampling input	
MARK	J7-1	J7-2	J7-3	J7-4	J7-5	J7-6	J7-7	J7-8
Definition	IN1+	IN1-	IN2+	IN2-	IN3+	IN3-	RSD+	RSD-
Function	Reserve for spare						+12Voutput	12VGND
MARK	J14-1	J14-2	J14-3	J14-4	J14-5	J14-6	J14-7	J14-8
Definition	CANL2	CANH2	CANL2	CANH2	RS485A1	RS485B1	PV C	PV C
Function	Parallel CAN communication				Meter communication		PV control	
RJ45-	1	2	3	4	5	6	7	8
BMS	RS485B3	RS485A3	NC	CANH	CANL	NC	RS485A3	RS485B3
Function	BMS-485 communication			BMS-CAN communication			BMS-485 communication	
Parallel_A	CANH1	CANL1	SNY-01	SNY-02	ISOGND1	ISOGND1	CAN-SMH	CAN-SML
Function	Parallel synchronous communication							
Parallel_B	CANH1	CANL1	SNY-01	SNY-02	ISOGND1	ISOGND1	CAN-SMH	CAN-SML
Function	Parallel synchronous communication							
Meter_485	RS485B1	RS485A1	NC	NC	NC	NC	RS485A1	RS485B1
Function	Meter communication						Meter communication	
MODBUS	RS485B4	RS485A4	NC	RS485A2	RS485B2	NC	RS485A4	RS485B4
Function	EMS monitoring		Reserve background monitoring communications			EMS monitoring		

## 2.3 Wall mount

Warm reminder, the equipment chassis is very heavy, please take it out carefully!

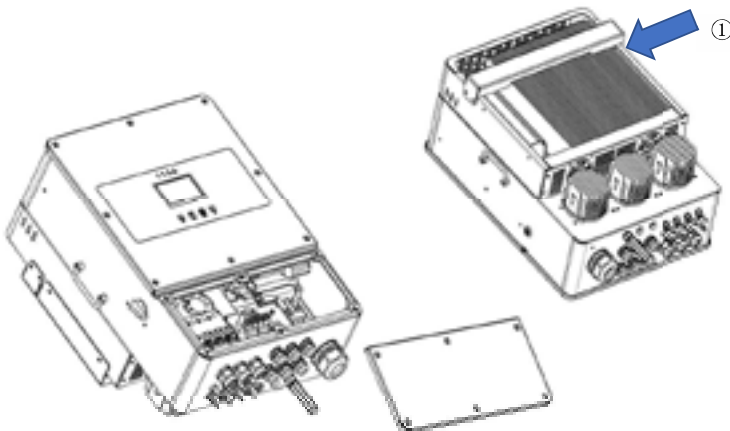

Figure 2.7 schematic diagram of device cover removal



- Take the equipment out of the package and secure the small bracket to the equipment with 4 M6 × 16 bolts, as marked ① in figure 2.7. tighten the bolts, remove the large bracket from the back of the equipment, and mark the installation wall according to the four bolt position dimensions 250X200mm in the middle of the large bracket panel in figure 2.8.
- Select the recommended bit shown in figure 2.8 below to drill 4 holes in the wall with a depth of 52-60 mm.
- Use a suitable hammer to load the expansion bolt into the hole, fix the back cover plate to the bolt on the wall, and tighten the screw head of the expansion bolt.
- Carry the equipment and hold it, make sure that the small bracket of the equipment is aligned with the large bracket of the rear cover, and fix the equipment to the fixed rear cover plate on the wall.
- Ensure that the equipment is aligned with the four bolt holes on the side of the rear cover plate, tighten the four bolts on the side of the equipment and the rear cover plate, and complete the installation.

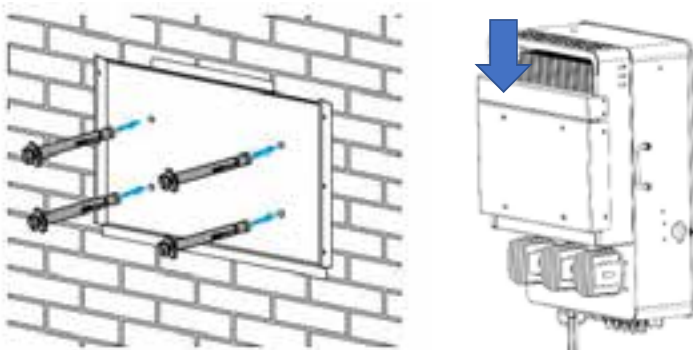

Fig. 2.8 schematic diagram of borehole location

## 2.4 Battery wiring work

For safe operation and compliance, a separate DC circuit breaker is required between the battery and the equipment. In some applications, switchgear may not be required, but circuit breakers still need to be disconnected. For the required fuse or circuit breaker specifications, please refer to the typical data selection in Table 2.3 below.

### 2.4.1 Battery Power Cable Wiring

For your safety and efficient operation of the equipment, please connect the battery with a suitable cable to reduce the risk of injury. You can also refer to the recommended cable shown in Table 2.3.

Table 2.3 Recommended cable example



All wiring must be carried out by professionals!

	Rated Power	Cable size	Cable size <sup>2</sup> mm	Torque value
Bat side	10 kW	3/0AWG	70	24.5Nm
	8 kW	1/0AWG	50	24.5Nm
	6 kW	1AWG	35	24.5Nm
	5 kW	1AWG	35	24.5Nm
	Rated Power	Cable size	Cable size <sup>2</sup> mm	Beeaker Current
AC side	10 kW	6 AWG	10	63A
	8 kW	8 AWG	6	63A
	6 kW	8 AWG	6	63A
	5 kW	8 AWG	6	63A

Please select the appropriate battery cable and bolt, find the "Battery end hole" in the schematic diagram of "Figure 2.8 Definition Diagram of Socket Terminal at the Bottom of Equipment", and insert the cable into the correct through hole. Tips: Please pay attention to the positive +, negative - corresponding wiring . Use a suitable screwdriver to unscrew the bolt, install the battery cable terminal, and then use the screwdriver to tighten the bolt to ensure that the bolt is tightened, the torque is 24.5Nm, clockwise, to ensure that the polarity of the battery and inverter is correctly connected.

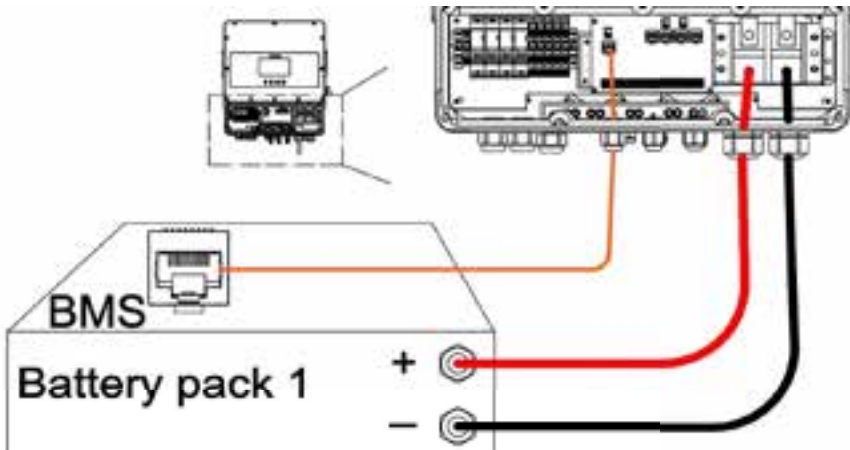

Figure 2.9 Schematic diagram of battery communication connection

Before making the final DC connection or closing/disconnecting the DC breaker, make sure that the battery positive + must be connected to the inverter positive + and the battery negative - must be connected to the inverter negative -. Reversed battery connections can damage the device.

## 2.4.2 Battery communication cable connection

As shown in Figure 2.9, the BMS of BAT\_PACK is connected with the J5 network port in the figure, and the definition of the communication connection line is shown in Table 2.2.

## 2.5 Power grid, load, GEN wiring

Before connecting to the grid, please install a separate AC circuit breaker between the equipment and the power grid. In addition, it is recommended to install an AC circuit breaker between the spare load and the equipment. This ensures that the inverter can be safely disconnected during maintenance and is fully protected from overcurrent. It is recommended that the AC circuit breaker is 63A. The recommended AC cable size is 12AWG, with each 4~6mm<sup>2</sup> cable. There are three terminals marked "Grid", "Load" and "GEN". Please do not mistakenly connect input and output connectors.

All wiring must be performed by qualified personnel. Using a suitable cable for AC input connection is very important for the safe and efficient operation of the system. To reduce the risk of injury, use the correct recommended cable, as shown in figure 2.10 below.



Please make sure that the AC side power supply is open before connecting.

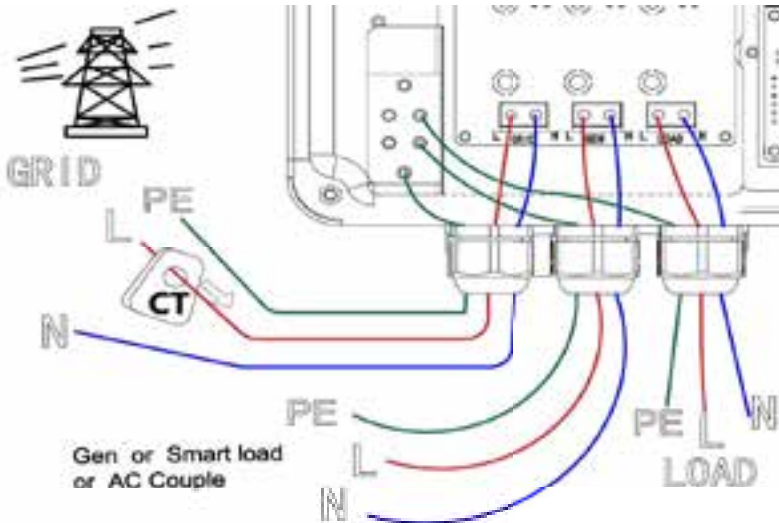

Figure 2.10 connection of power grid, load and engine

Follow these steps to connect the Grid grid, Load load, and Gen generator ports:

- Be sure to turn off the AC circuit breaker or isolation switch before connecting the power grid, load, and generator.

- Remove the 10mm long insulating sleeve, unscrew the bolts, insert the wire according to the polarity marked on the terminal, and tighten the wiring screw. Make sure the connection is complete.
- Then insert the AC output wire according to the polarity marked on the terminal and tighten the terminal. Be sure to connect the corresponding N and PE wires to the relevant terminals to ensure that the wires are firmly connected.
- Electrical appliances such as air conditioners need at least 2-3 minutes to restart because they need enough time to balance the refrigerant gas in the loop. If a power shortage occurs and recovers within a short period of time, it will cause damage to the equipment you are connected to. To prevent such damage, check whether the air conditioner manufacturer is equipped with a delay function before installation. Otherwise, this equipment will trigger an overload failure and cut off the output to protect your equipment, but sometimes it will still cause internal damage to the air conditioner.

## 2.6 Photovoltaic wiring

Before connecting the photovoltaic module, install a separate DC circuit breaker between the device and the photovoltaic assembly. Connecting photovoltaic modules with appropriate cables is very important for the safe and efficient operation of the system. To reduce the risk of injury, the recommended cable size is 12AWG, each 4mm<sup>2</sup> cable.

To avoid any failure, do not connect any photovoltaic components that may leak to the device. For example, a grounded photovoltaic module can cause current leakage to the device. Photovoltaic junction boxes with surge protection are required. Otherwise, when the photovoltaic module is struck by lightning, the equipment will be damaged.



**When using photovoltaic modules, make sure that there is no grounding.**

- When using photovoltaic modules, make sure that there is no grounding
- 1.The open circuit voltage  $V_{oc}$  of the photovoltaic module does not exceed the maximum open circuit voltage of the photovoltaic array photovoltaic integrated storage machine.

Table 2.4 description of photovoltaic module selection

Item	5KW	6KW	8KW	10KW
PV Input Voltage	370V(125V~500V)			
MPPT Range	150V~425V			
No. of MPPT Tracker	2			
No. of String Per MPPT Tracker	1+1	1+1	2+2	2+2

2.The open circuit voltage  $V_{oc}$  of the photovoltaic module should be higher than the minimum starting voltage of the integrated photovoltaic storage machine.

- Photovoltaic module wiring

- 1 Turn off the main AC circuit breaker of the power grid.
- 2 Close the DC circuit breaker.
- 3 Assemble the photovoltaic input connector as shown in Figure 2.11 at the bottom of the device.



Safety tips: Do not ground the positive or negative electrode of photovoltaic panel device, otherwise it will seriously damage the inverter.



Safety tip: Before connecting, please ensure that the polarity of the output voltage of the photovoltaic panel device is consistent with the "DC+" and "DC-" symbols.



Safety tip: Select a qualified DC cable: 4~6mm<sup>2</sup> 12~10AWG single cable .

Safety tip: Before connecting the inverter, ensure that the open circuit voltage of the photovoltaic panel device is within 1000V

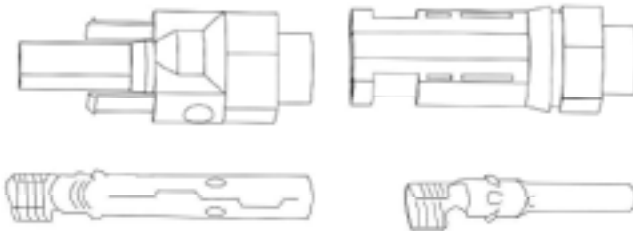

Figure 2.11 Photovoltaic input connector: DC+ connector left DC-Connector right

- The steps for assembling DC connectors are as follows :

- 1.Peel off the DC line about 7mm and remove the connector cover nut see figure 2.12 .

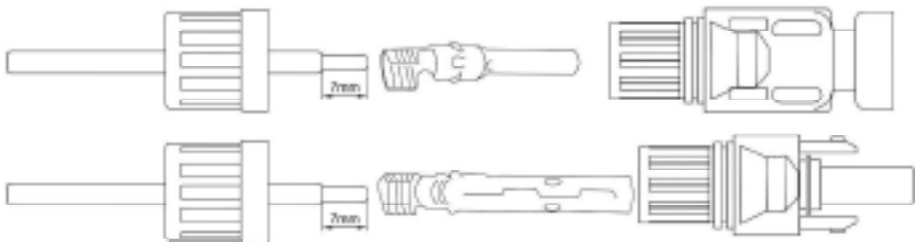

Figure 2.12 Connector cover nut

- 2.Crimp the metal terminal with crimping pliers, as shown in figure 2.13.

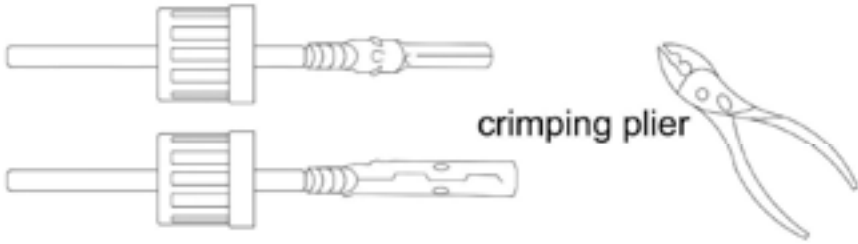

Figure 2.13 Crimping clamp crimping metal terminal

3. Insert the stylus into the top of the connector and screw the cover nut to the top of the connector. figure 2.14 .

4. Finally, insert the photovoltaic DC connector into the positive and negative input of the Hybrid inverter, as shown in figure 2.15.

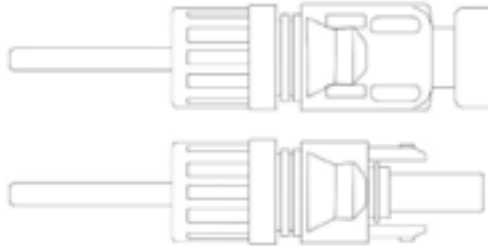

Figure 2.14 Stylus inserted into the top of the connector



Figure 2.15 The DC connector is inserted into the positive and negative input of the hybrid inverter equipment.



Warning: sunlight on the panel will generate voltage, high voltage series may be life-threatening. Therefore, before connecting the photovoltaic DC input line, the solar panels need to be blocked by opaque materials, and the DC switch should be turned off, otherwise the high voltage of the equipment may be life-threatening.

## 2.7 CT wiring

In the power grid cable, as shown in figure 2.16, three current transformers are passed through three phases, the direction arrow of the transformer faces the equipment side, and the transformer sampling line reaches the internal interface board J6 sampling terminal through the equipment COM3 through hole. At the same time, the J6 terminal is connected to the battery temperature sampling signal line.

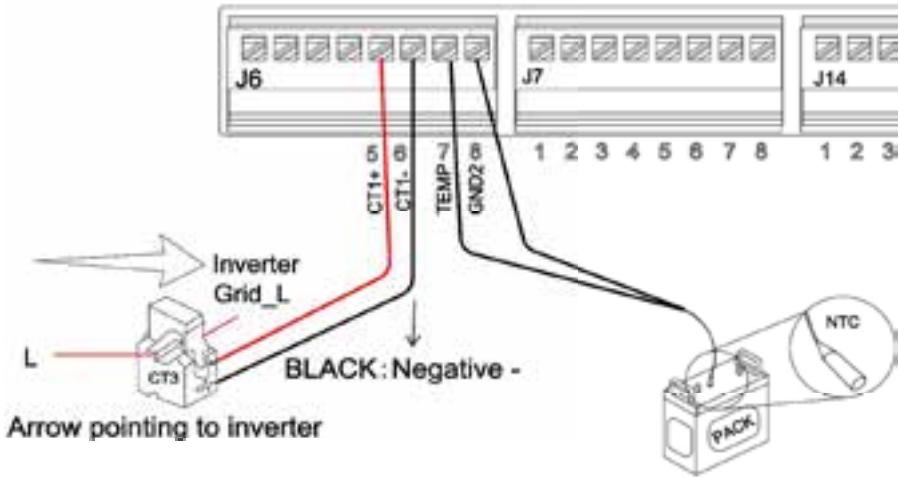

Figure 2.16 schematic diagram of external CT wiring and battery temperature sampling wiring

## 2.8 Meter connection

As show in figure. 2.17 Meter wiring diagram. The line shows the Eastron SDM230 is connected. See the actual model wiring.

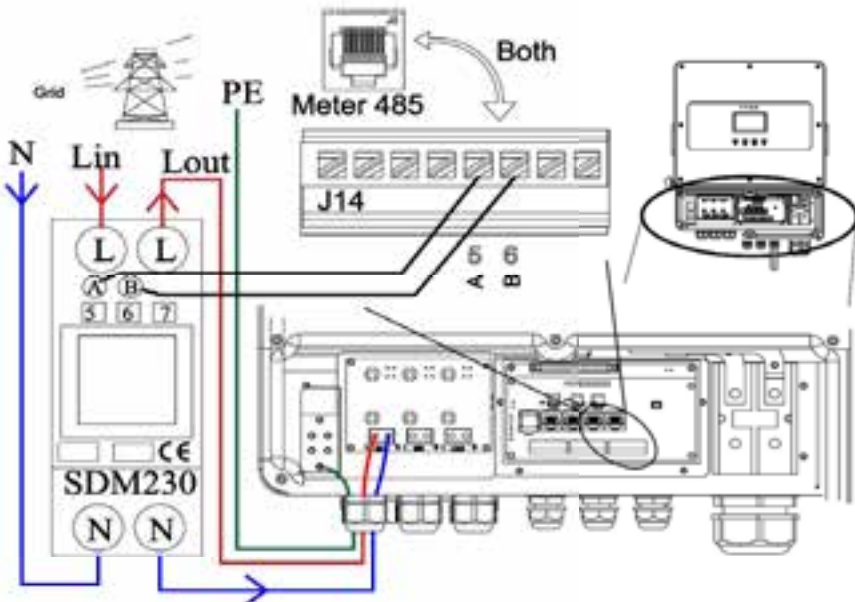



Fig. 2.17 Meter wiring diagram

## 2.9 Ground connection

To prevent electric shock, connect the ground cable on the power grid side to the inverter. Fasten the bottom line in the "ground" bolt hole as shown in Figure 2.18 .

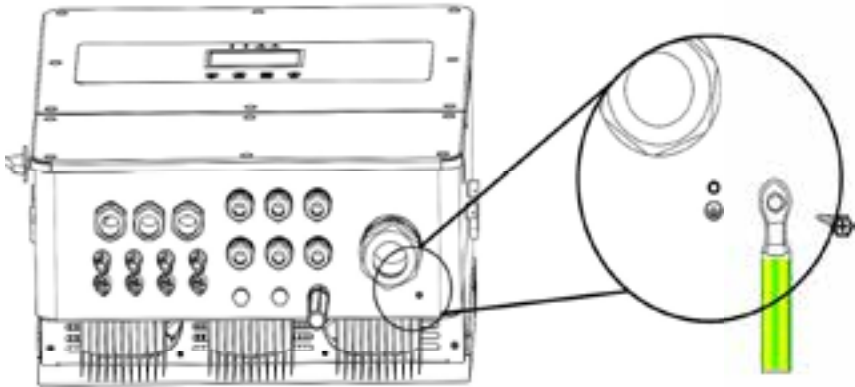

Fig. 2.18 Schematic diagram of equipment grounding

## 2.10 WIFI connection

For the configuration of Wi-Fi, please refer to the schematic wiring of Wi-Fi socket, and refer to the user manual of WIFI socket for details.

## 2.11 Stand-alone operation system diagram

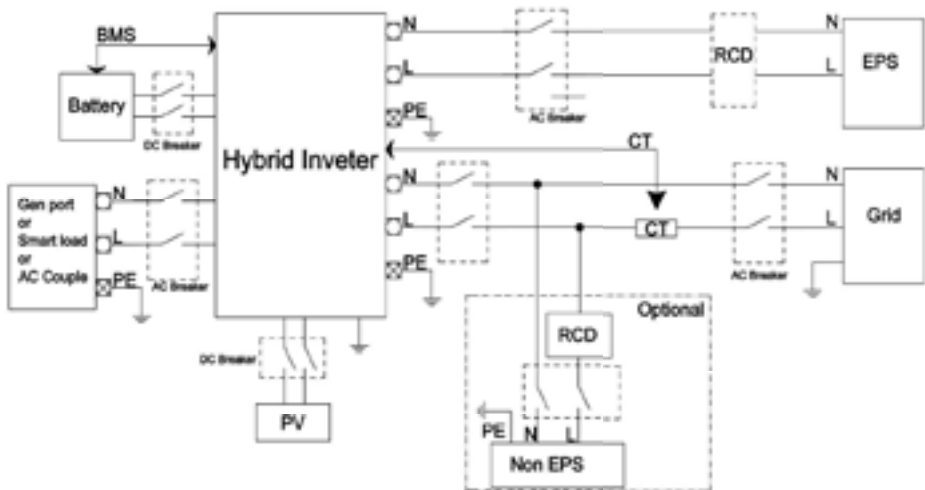

Figure 2.19 schematic diagram of stand-alone wiring



# 3 Display and setup

## 3.1 Run data display instructions

Note: All LCD passwords are 666666

The topology of the LCD screen is shown in Figure 3.1, and the main interface is shown in Figure 3.2A. The main screen displays information including solar energy, grid, load and battery. It also shows the direction of energy, shown in Figure 3.2B. flow by dots, so the system information is displayed vividly on the main screen, and the photovoltaic power and load power are always positive. Negative grid power means that it is connected to the grid, and positive means it is obtained from the grid. The negative pole of the battery power supply is charged, and the positive pole is discharged. The bottom icons are "Home", "Setting", "Events", "DeviceInfo".



Figure3.2A LCD Main interface

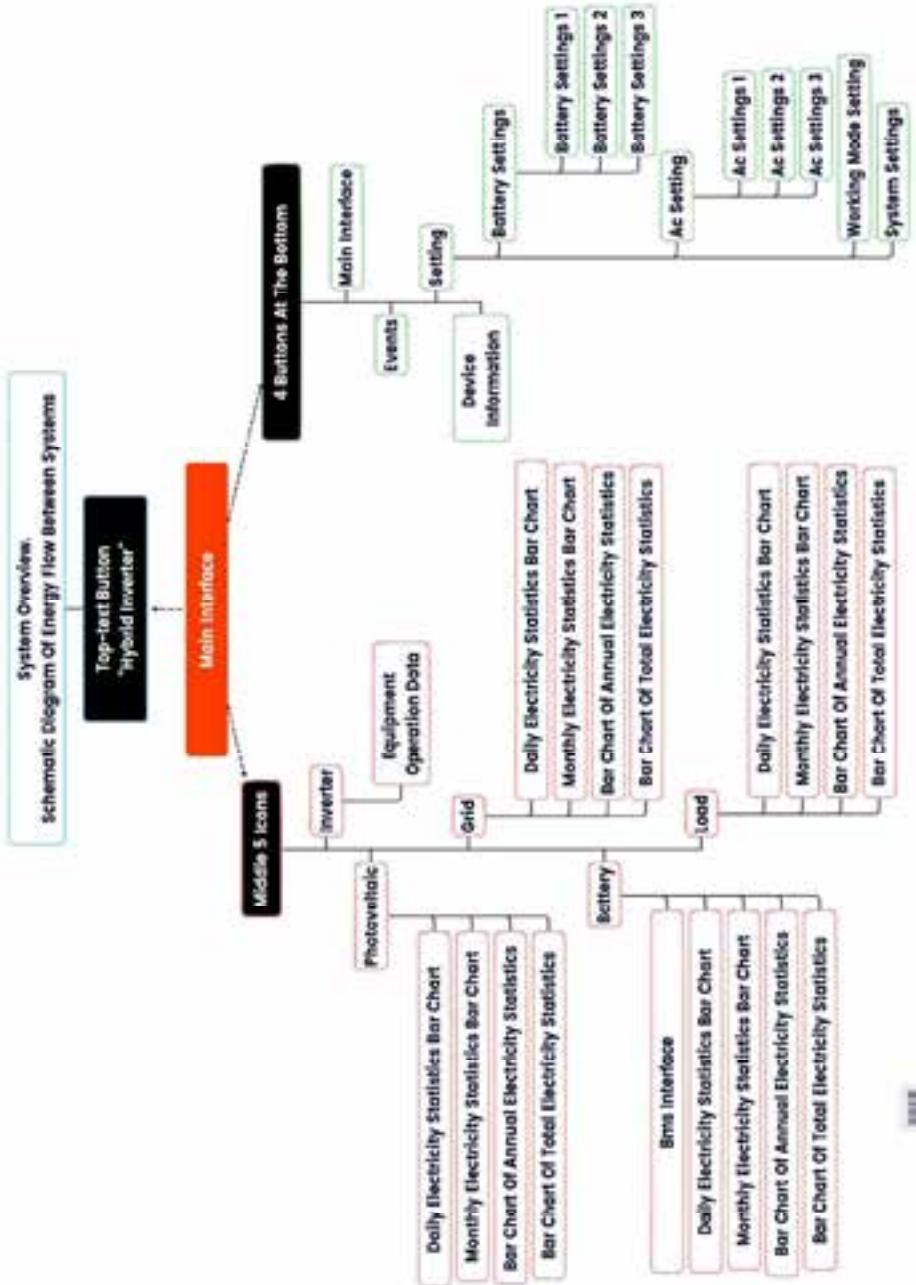

Figure3.1 LCD Topology structure diagram



Figure 3.2B System Overview

### 3.1.1 Photovoltaic data

Click the photovoltaic panel icon on the panel of the main interface to view its annual, monthly, daily, and current electricity statistics, as shown in Figure 3.3~3.6 below. The meaning of “Stage” on the left side of the interface is shown in Table 3.1. Click DEL on this interface to delete all photovoltaic power statistics. Click the arrow on the right side of the interface to view the data of other dates.



Figure 3.3 Annual Statistical Data of Photovoltaic Power Generation

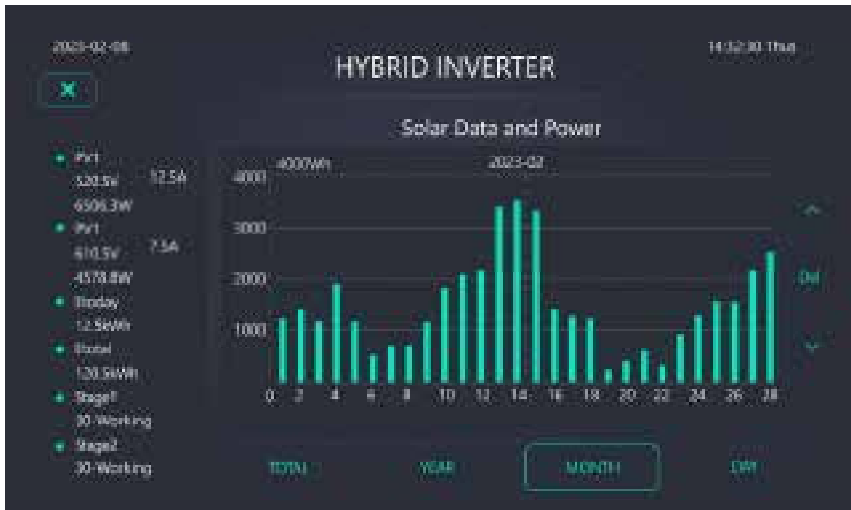

Figure 3.4 Monthly Statistical Data of Photovoltaic Power Generation

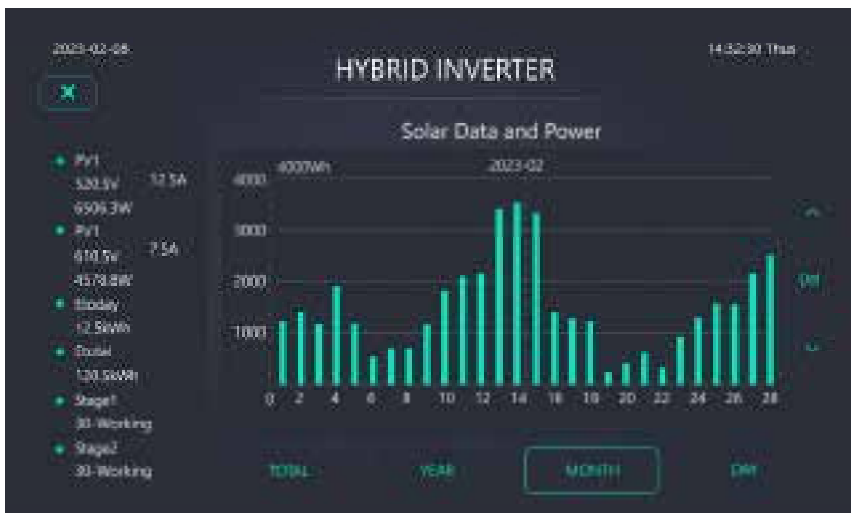

Figure 3.5 Daily statistical data of photovoltaic power generation

Table3.1 PV stage illustrate

Stage	Number	Illustrate
PV Stage	101~201	Shutdown
	98	Standby
	30	Normal working



Figure 3.6 All measurement data of photovoltaic power generation

### 3.1.2 Battery data

Click the battery icon on the main interface to view its annual, monthly, daily, and current battery statistics, as shown in Figure 3.7A below.



Figure 3.7A Statistical diagram of battery power data, etc.

The meaning of Stage on the left side of the interface is shown in Table 3.2. Click DEL on this interface to delete all battery statistics. Click the arrow on the right side of the interface to view the data of other dates.



Figure 3.7B Battery information diagram

Table 3.2 DC stage description

Stage	Number	Illustrate
DC Stage	102~129	Protect shutdown
	101	
	201	Shutdown
	231	
	89	Standby
	10	Normal off-grid operation

### 3.1.3 Inverter data

Click the middle inverter icon on the main interface to view the running data, as shown in Figure 3.8 below. The meaning of Stage on the right side of the interface is shown in Table 3.3



Figure 3.8 Schematic diagram of inverter operation data

Table 3.3 INV-Stage illustrate

Stage	Number	Illustrate
INV Stage	102~129	Protect shutdown
	101	
	201	Shutdown
	231	
	90	Wait for DC to power on
	89	Standby
	30	Normal grid-connected operation
	10	Normal off-grid operation

### 3.1.4 Grid data

Click the grid icon on the main interface to view its annual, monthly, daily, and current electricity statistics, as shown in Figure 3.9 below. Click DEL on this interface to delete all grid electricity statistics. Click the arrow on the right side of the interface to view the data of other dates



Figure 3.9 Statistics of power grid electricity data

### 3.1.5 Load data

Click the load icon on the main interface to view its annual, monthly, daily, and current electricity statistics, as shown in Figure 3.10 below. Click DEL on this interface to delete all load power statistics. Click the arrow on the right side of the interface to view the data of other dates.



Figure 3.10 Load power data and other statistics



## 3.2 Run parameter setting

Note again: the password is 666666 when setting the LCD of this device.

Click the "Settings" icon on the main interface to enter the system setting interface, as shown in Figure 3.11, from left to right are "Battery Settings", "Grid Settings", "Professional Settings", and "System Settings".



Figure 3.11 System setting interface

### 3.2.1 Battery parameter setting

Click "Battery Settings" to set battery-related parameters, as shown in Figure 3.12~Figure 3.14, "Battery Settings1~3", divided into 3 parts.

a. The first part batterySetting1 is the battery setting ①: The upper and lower limits of the battery voltage, the upper limit and maximum current of PV1 and PV2 voltage, and the maximum charging and discharging current can be determined.

**Bat capacity AH:** it tells hybrid inverter to know your battery pack size.

**"Battery charge and discharge current setting":** For AGM and Flooded, we recommend using Ah battery size x 20%= charge/discharge current. For lithium batteries, we recommend Ah battery size x 50%= charge/discharge amps. For GEL lead-acid batteries, follow factory recommendations.

**Bat Mode:** Select one of "Lithium","Use Bat V" or "Use Bat %" for all the setting.This will affect ②,③ in that Figure 3.12 and ②,③ in that Figure 3.15 settings below.

b. Part ② is the maintenance setup for lithium batteries or battery SOC control

- Lithium Mode :This is BMS protocol.Please reference the document Apprived Battery .
- Shutdown,If the SOC is below this setting, the inverter will shut down.
- Low Bat,If the SOC is below this setting, the inverter will alarm.
- Restart,The device will resume operation when the SOC reaches the set value and the AC output will resume.
- TempCorrEn,When this option is checked, the temperature compensation of the float or average charge in ④ will take effect.
- CirEn, Battery CAN communication is able to look for signal enable. When the battery communication mode is set to CAN on the System setting screen in Figure 3.18, please tick this setting. When you want to control the lithium battery with voltage mode, you can remove this check mark.
- BatActEn, The automatic battery activation function is enabled. After this option is selected, the device will automatically activate the battery when the battery is protected.

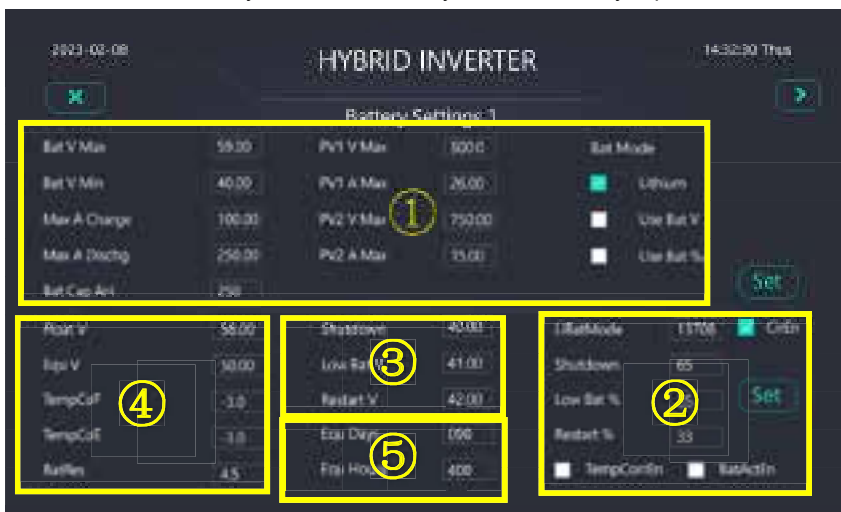

● Figure 3.12 Battery Setting 1 Interface

c. Part ③ deals with maintenance settings when battery voltage is controlled Parameters can be set as required.it means:

- Shutdown,If the battery voltage is below this setting, the inverter will shut down.
- Low Bat,If the battery voltage is below this setting, the inverter will alarm.
- Restart,The device will resume operation when the battery voltage reaches the set value and the AC output will resume.

NO.④⑤ in that figure,3.12 Other battery maintenance settings.According to the setting values of different voltage types in Table 3.1, the default value of temperature compensation coefficient TempCoF/E is -3. Professional installers use, if you do not know, you can choose not to modify the default.

Battery Setting23:The interface is for power grid and engine power, voltage, upper limit of charging and discharging current, battery operation mode, time curve operation mode, etc. If you are not clear, you can choose default without modification.



Figure 3.13 Battery Setting 2 Interface

When setting battery Settings 2, please note whether the battery Mode is SOC control mode or voltage control mode (battery Settings 1 Bat Mode set check box)

- Dischg Pmax-W :The maximum power that the battery can discharge.
- Stop Dischg SOC-% : The SOC value of the battery stops discharging. If the SOC is lower than this value, the battery will no longer discharge.
- AC Chg SOCmax-%: The maximum SOC value of battery charging, above which the battery SOC will no longer be charged with the grid or gen. When the“General Stop Chg SOC-%” is higher than this value, the PV will continue to be charged to the minimum value of the Disable SOC.
- General Stop Chg SOC-% : The minimum SOC value of the battery charge, AC and photovoltaic side are no longer charged.
- Dischg Vmin-V: Minimum battery discharge voltage. If the battery voltage is lower than this value, the battery will not discharge.
- Chg Vmax-V: Maximum battery charging voltage. If the battery voltage is higher than this value,

the battery will not be charged.

- Chg I<sub>max</sub>-A: The maximum current allowed when the battery is charged.
- Gen Stop SOC-%: When no Grid, the battery SOC value is higher than this value, the Gen will automatically stop.
- Gen Start SOC<sub>max</sub>-%: When no Grid and the battery SOC value is lower than this value, the Gen will automatically starts for charging the battery.
- Gen Stop Vol-V: When no Grid, the battery voltage value is higher than this value, the Gen will automatically stop.
- Gen Start Vol-V: When no Grid and the battery voltage value is lower than this value, the Gen will automatically starts for charging the battery.
- Chg I<sub>max</sub> - A: the maximum current value of the battery when charging.



Figure 3.14 Battery Setting 3 Interface

Table 3.1 Recommended settings for different batteries

Battery Type	Absorption stage	Float stage	Torque value
			Per 3hours per 30 days
AGM or PCC	14.2V 57.6V	14.4V 53.6V	14.2V 57.6V
GEL	14.1V 57.4V	14.4V 54.0V	
WET	14.1V 59V	14.4V 55V	14.7V 59V
LITHIUM		Per their BMS decision	

### 3.2.2 Grid parameter setting

Click "Grid Setting" to set grid related parameters, as shown in Figure 3.15, You can set the meter or CT access type, meter model and communication address, CT ratio, voltage frequency upper and lower limits, GEN interface type, inverter voltage amplitude, Grid voltage amplitude range, Grid

frequency range, Grid power limit value, Gen port access type, smart load and AC coupling device function Settings.



Figure 3.15 AC Setting 1

### 3.2.3 GEN port function settings



Figure 3.16 AC Setting 2

When the GEN port can be connected to the Gen, intelligent load or AC coupling unit grid-connected inverter, it is necessary to change the GEN interface type in the setting to the corresponding type. The setting path is shown in Figure 3.16 below. Click GenPortType to select the Gen interface type as Generator, Smart loads or AC Couple. Please select according to the actual wiring.

- When selecting the Gen connected to the GEN interface, please confirm that the control line of the Gen is also connected to the J6 1/2 terminal NO2&COM2 Gen adjustment control, J6 3/4 NO1&COM1 Gen start control, select GenPortType as Generator in the grid setting interface in Figure 3.16. At this time, Select Gen Mode, choose one of the two Modes, when the power grid is cut off, and the battery voltage or SOC is lower than the battery discharge voltage or SOC set

value, the Gen will automatically start to supply power to the system.

- When selecting the smart load connected to the GEN interface, select GenPortType as Smartloads in the grid setting interface in Figure 3.16, and the Gen relay will be turned on at this time, and the GEN interface will supply power to the smart load for output.

StartPower: The smart load is set to the power settings. When the photovoltaic power is greater than the setting of this settings, the inverter will power the smart load power.

Couple Fre Hz: AC coupler frequency setting.

Off Soc%: When the battery SOC% is lower than the set value, the inverter will stop supplying power to the Smart load.

On Soc%: When the battery SOC% is higher than the set value, the inverter will start supplying power to the Smart load.

Off Vol V: When the battery voltage is lower than the set value, the inverter will stop supplying power to the Smart load.

On Vol V: When the battery voltage is higher than the set value, the inverter will start supplying power to the Smart load.

- When selecting the AC Couple connected to the GEN interface, select AC Couple as GenPortType in the grid setting interface in Figure 3.16, and then AC Couple and the grid supply power to the system together.

Off Soc%: When the battery SOC% is higher than the set value, the AC couple will not participate in the system power supply.

On Soc%: When the battery SOC% is lower than the set value, the AC couple and the inverter are connected to the grid to supply power to the system.

Off Vol V: When the battery voltage is higher than the set value, the AC couple does not participate in the system power supply. .

On Vol V: When the battery voltage is lower than the set value, the AC couple and the inverter are connected to the grid to supply power to the system.

Only Bat En: When the battery is working, the system will always power the Smart Load.

OnGrid Always on: When the inverter is working On grid, the system will always power the Smart Load.

Gen Pmax kW: This value is the maximum power value of the external Gen, and the system will regulate the system according to this value

Gen Signal EnOutput Gen signal control enablement, including power on and off and speed control control.

Gen Mode According to different types of Gen, inverter operation mode is different, most equipment choose MODE2, if the main interface does not show that the Gen participates in system operation, please switch MODE1.

### 3.2.4 CT transformation ratio setting

Click the CT Ratio data box in the grid setting interface in Figure 3.15 to set the CT transformation ratio. When the model of transformer is 100:50mA, the interface value shall be filled with 100. If the transformer is 150:50mA, the value should be 150

The slave value is very important. The wrong setting will affect the normal operation of the equipment. If you are not sure, please keep the default or contact.us



Figure 3.17 Intelligent Load and CT Ratio Setting Path

### 3.2.5 Safety setting

Table3.2 Grid standard code

Number	Area description	Grid standard code
0	Generic standard	Generic standard
1	Pakistan	IEC61727/PK
2	Pakistan	NRS/ZA
3	Germany.	VDE4105/DE
4	Germany.	EN50549
5	Poland	EN50549-PL
6	Italy	CEIO-21/IT

Figure 3.18 AC setting interface 3, mainly for safety setting. Specific function Settings are defined as follows:



Figure 3.18 AC setting interface 3

- Saft Standard: Grid standard, see Table 3.2 .Grid standard code list will be updated from time to time, please refer to the actual product.
- Reactive Power Type Reactive power compensation type.① The reactive power is directly set. ②Fixed power factor at fixed.③By active power-power factor curve.④Reactive power-voltage amplitude curve (local grid standard).⑤ According to reactive power-voltage amplitude curve (common standard).

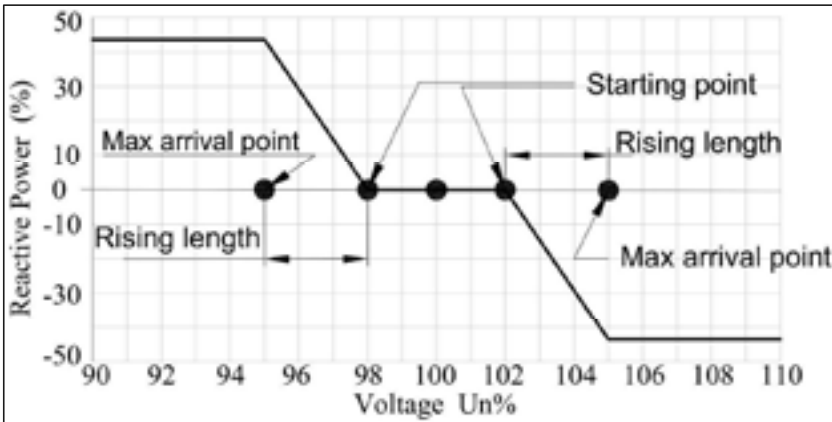

Figure 3.19 QU curve when power factor is 0.9,

- Reactive Power set directly:The reactive power is set directly. When this type is selected Please enter the value in Reactive Power VA.



- Fixed power factor: Fixed power factor. When this type is selected. Please enter the power factor value in Power factor set
  - Active power-PF curve By active power-power factor curve. When this type is selected. Please enter the power factor and the rate of active power rising in Power factor set and Rising Rate of active power. Note: The higher the speed setting, the slower the rise.
  - Reactive Power-Vol curve Reactive power-voltage amplitude curve abide by local grid standard.
  - Reactive Power-Vol curve Reactive power-voltage amplitude curve abide by Universal standard. Please set the following parameters as required: Starting point of Q-U% Rising length of Q-U%. For example, As shown in the figure 3.19, QU curve when power factor is 0.9, From the power factor of 0.9, we can calculate the maximum reactive power as  $43.59\% \times \text{apparent power}$  .
  - Starting point of QC: Starting point of capacitive reactive power.
  - Starting point of QL: Starting point of inductive reactive power.
  - MAX arrival point of QC : MAX arrival point of capacitive reactive power.
  - MAX arrival point of QL : MAX arrival point of inductive reactive power.
- Safety Time Enable: The safety time is enabled. After the system is powered off, the connection time for the device to restart is 12 seconds. Time after tick is 70s.
  - Filtering Set: Filter setting.
  - TimeConst of Filt: Reactive filter time constant. The default value is 120.

### 3.2.6 Operating Mode Settings

Click "Professional Setting" to select equipment operation mode, parallel operation quantity and address during parallel operation, Inv address of each equipment shall be set differently and cannot be repeated, for example, equipment AInv is 1 and equipment BInv can be set to 3, as shown in Figure 3.20. For details about the operation logic, see Operation and Maintenance.



Figure 3.20 Working mode setting interface

### 3.2.7 System Setup

Click "System Setting" to set relevant parameters of the system, as shown in Figure 3.21, including device time, LCD address, device serial number, read firmware status, BMS address, etc.

Click on the BMS PORT list to select the battery brand you are using. If multiple devices are used in parallel with one battery set, please tick BatShareEn. If the lithium battery uses CAN communication, tick CirEn in Battery Settings page 1. If you want to use voltage mode to control the battery, uncheck CirEn



Figure 3.21 System Setting Interface

### 3.3 Events Display

Click the "History" icon on the main interface to view all the running status and other information of the equipment, as shown in Figure 3.22. When the equipment runs abnormally, you can view this event record. For detailed handling opinions, please refer to "Table 4.2 Equipment Alarm Information and Handling Methods" in Section 4 Operation and Maintenance.

### 3.4 Device Info

Click the "DeviceInfo" icon on the main interface to view the equipment serial number, BMS communication protocol, BMS communication address, INV/DCDC software version, LCD software version HMI and other status information, as shown in Figure 3.23.

### Events Records

Order	Time	Record
1	2023-11-03 12:30:40	W03:W07_Fault_Warning
2	2023-11-03 12:30:40	W00:Grid_No_Voltage_Warning
3	2023-11-03 12:30:40	W02:Comm_LCD_Loss_Warning
4	2023-11-03 12:30:40	W05:PV2_low_voltage_warning
5	2023-11-03 12:30:40	W09:PV1_low_voltage_warning
6	2023-11-03 12:30:40	W07:Battery_low_voltage_warning
7	2023-11-03 12:30:40	W17:Grid_Phase_Seque_Fault
8	2023-11-03 12:30:40	W06:DC_OverCurr_Failure
9	2023-11-03 12:30:40	W13:Tr_Air_OverCurr_Fault

TPage: 72  
 RPage: 1  
 ↑  
 ↓  
 Del

Figure 3.22 Historical Information Interface

### Device Information

Order	Term	Version
1	Serial Number	W2012KAK9150001
2	BMS Protocol	Felcity
3	BMS Addr	1
4	BMS Com	RS485
5	INV Software	V0.7.0.1.2.E
6	DCDC Software	V0.7.0.0.2.C
7	Dis Software	V1.1.5.C
8	Protocol	V1.0.0.5
9	WFI Firmware	V1.0.0.3
10	Device Model	PV55-M14C-FA225-DD40

Figure 3.23 Equipment Information Interface

# 4 Operation and maintenance

## 4.1 Trial run

When the device and other device cables such as batteries are properly installed and connected, start the device by following the following steps: The LED flashing signal definition and LCD key definition are described in Table 4.1: Hold down UP and ENTER at the same time to restart the LCD.

- Turn on the power supply of grid, battery, photovoltaic switch, the LCD will light up.
- Select a meter or CT and set its address based on the actual used. If neither is used, select None .The setting position is on AC Setting1 on the LCD screen.
- Select a Grid standard based on the actual power grid usage. If no corresponding standard is available, select the general standard. The setting position is on AC Setting1 on the LCD screen.
- Select the battery control mode based on the actual use of the battery.This setting is located in the LCD battery device screen Battery Setting1.When the system is not connected to the battery, but is connected to the PV or power grid, in this case, the system can still work without selecting Bat Mode.
- Press the ON/OFF button to turn on the device.The round button located on the right side of the housing.
- For details about the operating mode, see descriptions of the single machine Operating Mode.

Table 4.1 Definition of LCD keys

	LED definition	Instructions
DC	The green light continues to shine.	Pv connection normal
AC	The green light continues to shine.	Power grid connection normal
Normal	The green light continues to shine.	Normal inverter operation
Alarm	Red light flashing	Fault or warning
ESC	Exit setting	
UP	Go to the previous option	
DOWN	Go to the next option	
ENTER	ENTER certainty	

## 4.1 Stand-alone operation and logic description

When the stand-alone operation, The K6 dialing code on the internal and external interface board of the device needs to be opened, set ON, as shown in Figure 4.1. K8 and K7 remain closed.

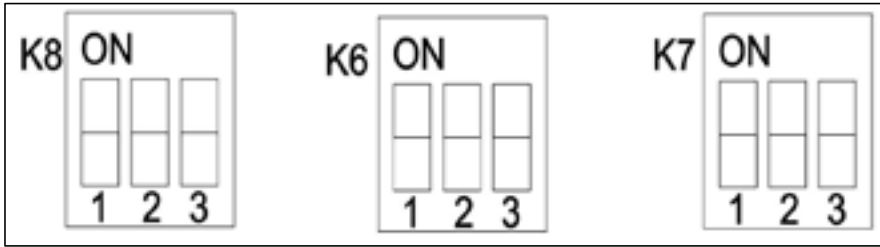

Figure 4.1 Schematic diagram of DIP terminal ON

#### 4.1.1 Enter working mode to set path

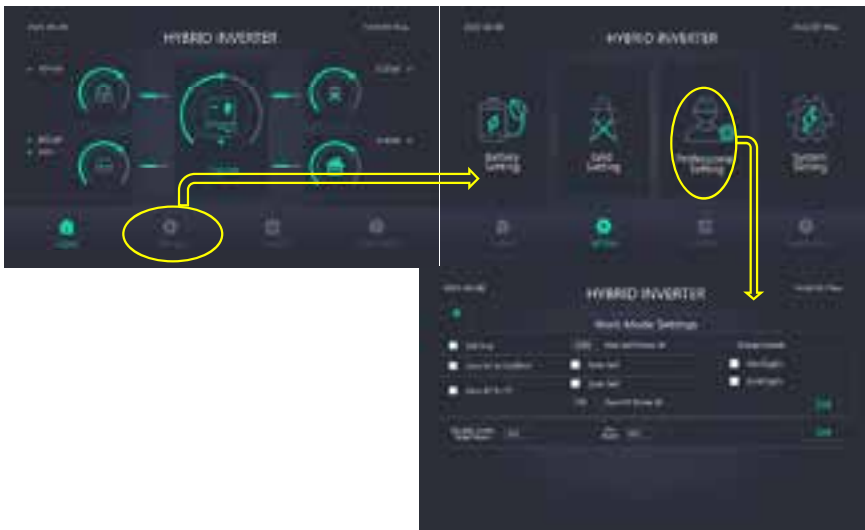

Figure 4.2 schematic diagram of entering the working mode

#### 4.1.2 Sell First

Priority mode of selling electricity. This mode allows hybrid inverters to sell excess photovoltaic power back to the grid, and it can also be sold to the grid when time permits and the battery energy is surplus when the current capacity of the battery is greater than the minimum discharge SOC. The minimum discharge voltage setting value, but the selling power should be limited, the total power set rule is the maximum load power and the power sold to the grid shall not exceed of its total inverter rated power. When photovoltaic power generation and battery energy can not meet the power consumption of the load, the power grid will be used as a supplementary power supply. At the same time, if time and conditions permit, you can also check "engine rechargeable" or "grid rechargeable"

to use the power grid or engine to charge the battery.

#### 4.1.3 Zero Ex To Grid Port

This mode hybrid inverter only supplies power to the connected "LOAD" local load. The hybrid inverter will neither provide power for the household load nor sell power to the grid. The built-in CT will keep the detected power flowing to the grid side to zero, while photovoltaic power generation will only provide the local load and charge the battery. When the photovoltaic power generation is strong, the battery is full, and the load cannot be consumed. The inverter will operate with limited power excess photovoltaic power can also be sold to the grid if time permits: this function can be checked . When photovoltaic power generation and battery energy can not meet the load, it will be supplemented by the power grid. At the same time, if time and conditions permit, you can also check "engine rechargeable" or "grid rechargeable" to use the power grid or engine to charge the battery.

#### 4.1.4 Zero Ex To CT

This mode hybrid inverter not only supplies power to the local load on the connected Load terminal, but also provides power to the home load. The external CT keeps the detected power flow to the grid side zero. Photovoltaic power generation can be provided to the local load and household load, and the battery can be charged. When the photovoltaic power generation is strong, the battery is full, and the load cannot be consumed. The inverter will operate with limited power excess photovoltaic power can also be sold to the grid if time permits: this function can be checked . When photovoltaic power generation and battery energy can not meet the load, it will be supplemented by the power grid. At the same time, if time and conditions permit, you can also check "engine rechargeable" or "grid rechargeable" to use the power grid or engine to charge the battery.

#### 4.1.5 Time curve mode

Power grid peak regulation. Click on the home page to set "SETTING", click on the battery setting "BatterySetting" graph in the settings interface, you can enter the battery parameter setting interface, click the next page, check "TimeofUse" on the "BatterySetting3" page, and set the time curve related parameters, as shown in figure 4.3 below, you can choose the three time curve operation modes of "SOC-%", "Power-W" or "Bat-V" in the drop-down box.

The hybrid inverter in this mode operates according to the set time period and the corresponding allowable conditions, and the battery discharge power will be limited to the set value. If the load power exceeds the allowable value, photovoltaic will be used as a supplement. If it still can not meet the load demand, then increase the grid power to meet the load demand. At the same time, if time and conditions permit, you can also check "engine rechargeable" or "grid rechargeable" in the working

mode interface to charge the battery using the power grid or engine.

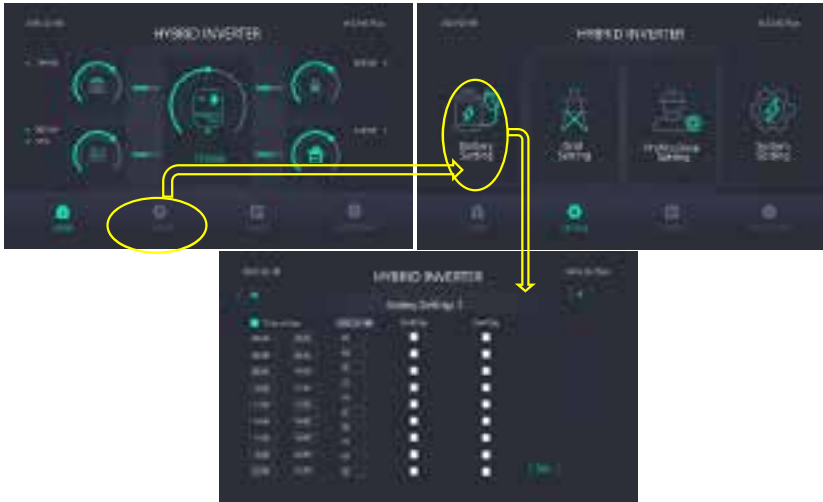

Figure 4.3 Schematic diagram of setting time curve

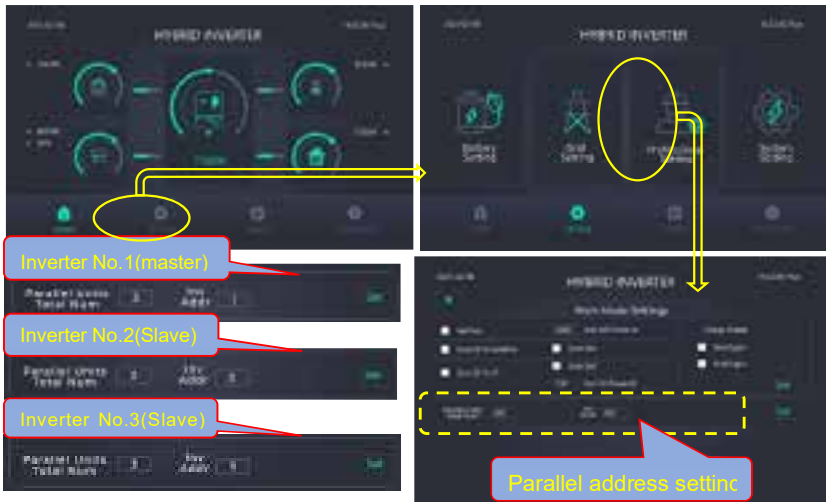

Figure 4.4 Enter the parameter setting diagram of the parallel machine and the address setting of the three machines

## 4.2 Parallel operation and logical explanation

When running in parallel, the internal and external interface board of the first device and the last device is placed as shown in Figure 4.1 K6 dialing code needs to be opened, "ON", K8 and K7 are currently closed. This is shown in Figure 4.5 for example, the grid-connected parallel wiring diagram, the three devices need to be placed, and the K6 dialing code of 1# and 3# needs to be opened, and the

dialing code of 2# does not need to be opened.

#### 4.2.1 Set entry path description

Click “Setting” ,display at screen on the home page, and click "Professional Setting" in the setting interface to enter the working mode setting interface and select the address setting of the device, as shown in figure 4.4.

#### 4.2.2 Parallel operation logic

When multiple parallel machines are connected, first connect the communication network lines ports Parallel\_A and Parallel\_B and CAN communication lines port J14CAN2HandCAN2L of the parallel equipment to form a ring connection system, then set the address parameters of each module respectively after power-on, as shown in figure 1.1. set the number of parallel machines "ParallelUnitsTotalNum", inverter address "InvAddr" can only be odd , HMI parameters address recommended starting from 1 can not be repeated. The hybrid inverter module of InvAddr=1 will be defined as the host by the system, and the hybrid inverter module whose InvAddr is odd will be defined as the slave.

In this mode, all hybrid inverters will run synchronously according to the scheduling of the host, so when powering up, the boot keys of all slaves should be pressed first, and finally the boot keys of the mainframe should be pressed, so that the host can automatically identify the slave state in the merging system, which is conducive to logic and power regulation when power is turned on and connected to the grid. If there is an individual slave failure or communication interruption in the normal operation, the host will automatically identify and withdraw the slave from the whole parallel system and re-regulate the power. When the fault slave returns to normal, the host will automatically identify and merge the slave into the system and re-regulate the power. All the working modes of the parallel system are the same as those of the stand-alone machine. It should be noted that the parallel machine only needs a set of external CT, which is connected to the municipal power trunk line, and the sampling signal is connected to the CT input port of the host computer.

#### 4.2.3 Parallel system wiring diagram

As shown in Figure 4.5 on grid parallel wiring diagram, Figure 4.6 off grid parallel machine wiring diagram. When the GRID or GEN or AC Couple is connected, it is connected to the grid at this time, and the parallel wire needs to be connected according to the diagram. When the GRID ,GEN and AC Couple are not connected, there is no need to connect the parallel wire for off-grid parallel operation at this time. When multiple devices share a set of batteries and are paralleled, select BatShareEn on the System Setting interface.



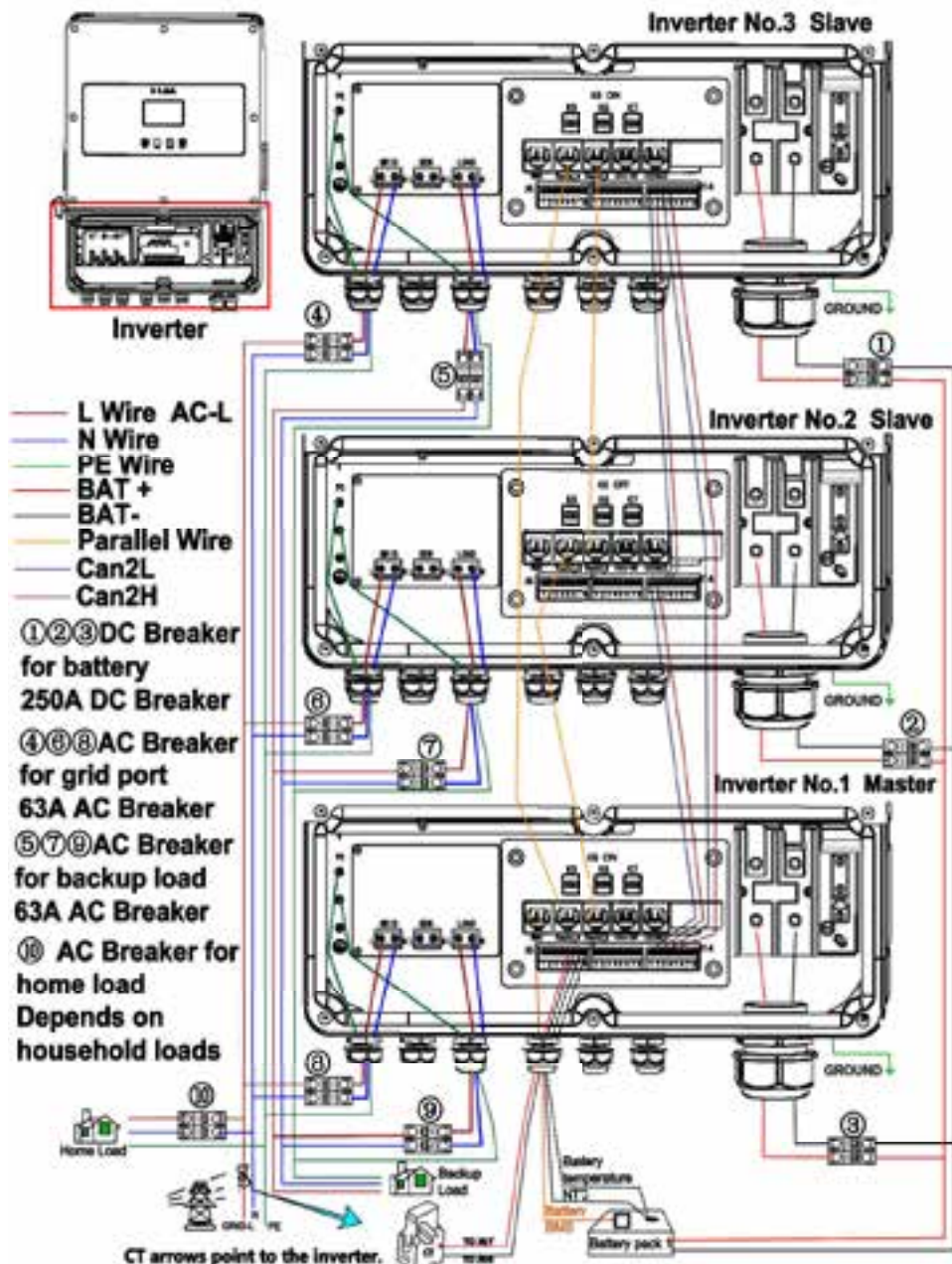

Figure 4.5 On-grid parallel wiring diagram

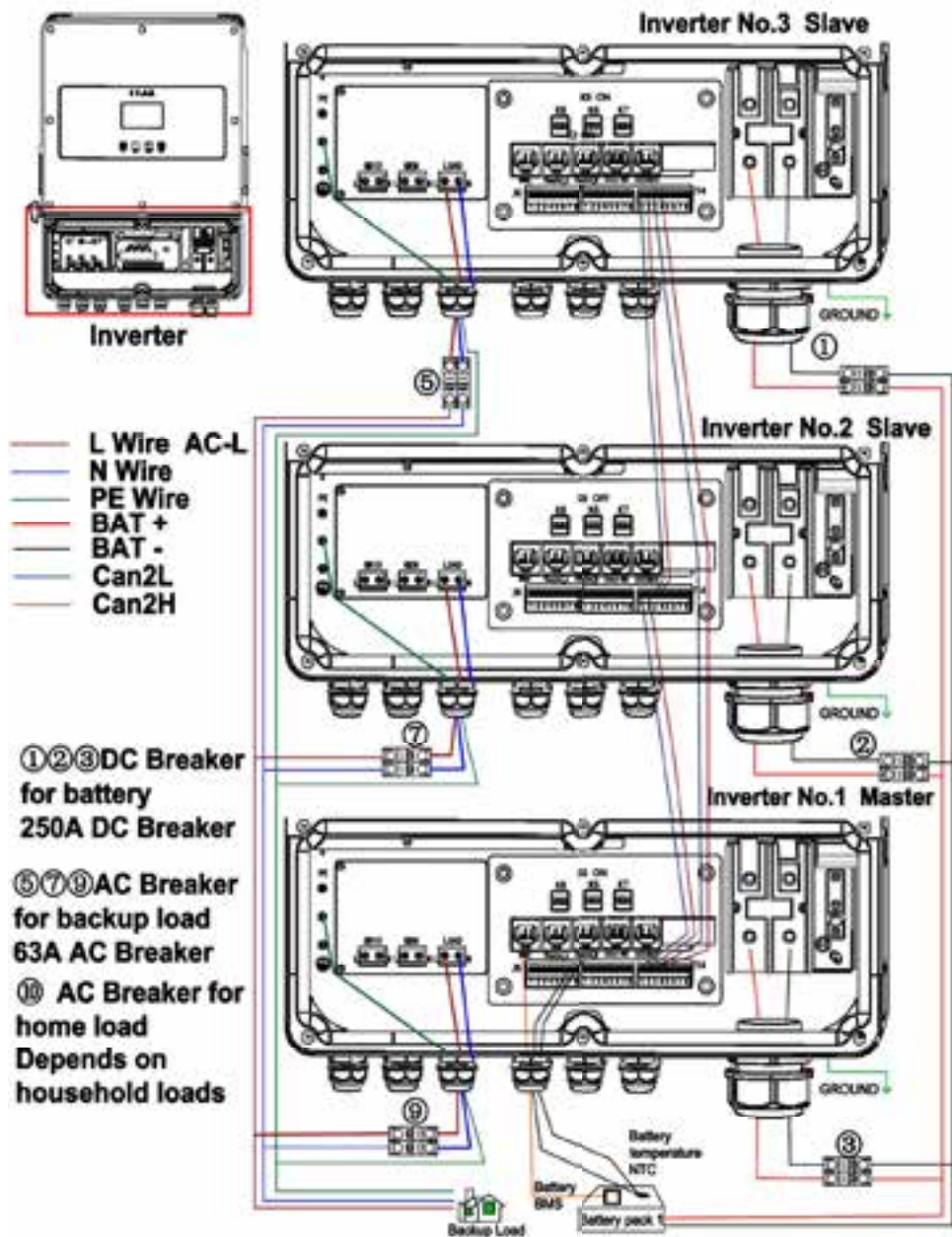

Figure 4.6 Off-grid parallel wiring diagram

### 4.3 Example of five parallel inverter

#### 4.3.1 Grid and load connection

Figure 4.7 below shows the connection diagram of five inverters (No. 1, 3, 5, 7, 9). K0 is the main circuit breaker of the power grid. K11, K13, K15, K17, K19 are load circuit breakers, K1 is the load circuit breaker. K02 is a home load circuit breaker. Each inverter has its own power grid circuit breaker respectively K01, K03, K05, K07, K09.

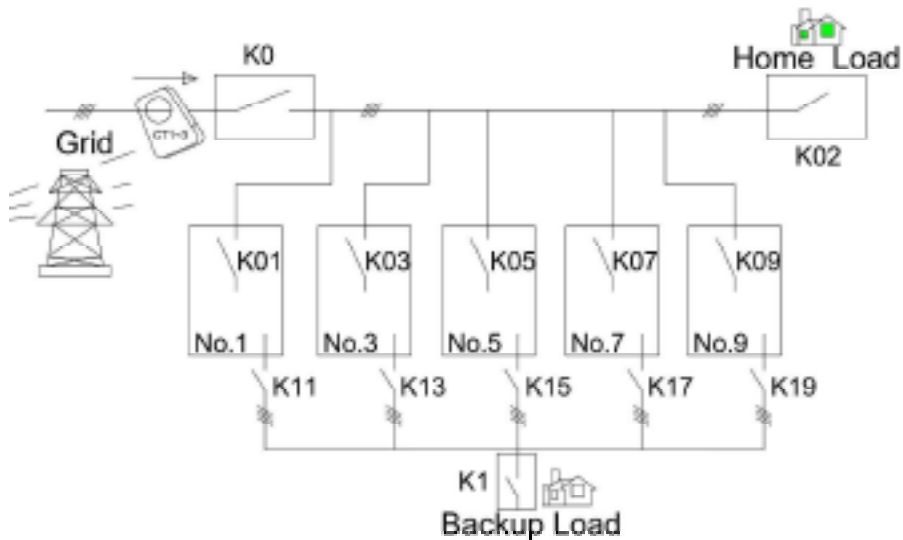

Figure 4.7 The connection diagram of five inverters

#### 4.3.2 Parallel cable connection and check

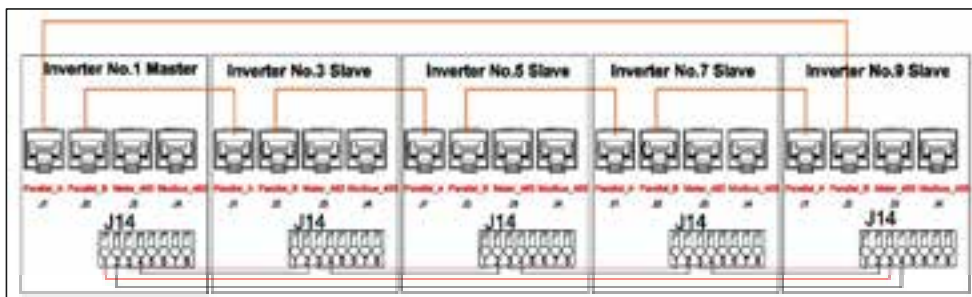

Figure 4.8 Parallel cable connection

Step 1:

a) Check whether the cable connection is correct as shown in Figure 4.7 (for BMS connection, CT or

ammeter connection, battery connection, and ground cable connection, refer to the previous chapter.)

Check whether the positive and negative batteries are consistent.

b) Please check whether the parallel cable connection is correct as shown in Figure 4.8.

c) Set the K6 DIP switch in the middle of the first and last inverters to ON, and turn off the others.

Step 2:

a) Only turn on the Grid circuit breaker K0.

b) Check the phase voltage of each inverter grid breaker (inside) input port, and check the same phase voltage difference between grid main break and inverter grid breaker is near zero. checking K01,K03,K05,K07,K09,if the voltage is not normal please check the wire connection between grid and inverter grid breaker. if the connection all normal, goto third step.

Step 3:

a) Turn on K01,K03,K05,K07,K09. Keep battery not add to inverter and those load breakers off(K11,K13,K15,K17,K19).

b) Check the display lcd screen is on, and the grid data page shown the grid voltage and frequency are normal.

c) For details about how to set the device address, see Figure 4.1.1 Settings. Set the host address to 1 and set the host address to 3, 5, 7, and 9.

d) Battery sharing Settings, if the same battery group is used, please check BatShareEn in system Settings, and set the BMS communication mode and communication address.

e) For CT or smart meter Settings, please select the metering mode used by the system in AC Settings1 if both are no-used, please select None.

f) To select the battery control mode, please select SOC control, voltage control or lithium battery control mode in Battery Setting1 according to the actual battery type. If the battery is not connected, you can run without selecting.

g) Turn on the button. The sequence is to close the slave 3#5#7#9# first, and finally close the master 1#).

h) After the grid relay is closed, check whether the voltage on the load page of the main screen is normal. Click the middle inverter icon on the main screen of each device to check whether the INV Stage is 30-Working.

i) Check the voltage difference of same phase between inverter grid input port and inverter's load output port ,make sure all voltage difference of each inverter are near zero.

j) Check the voltage difference of same phase between inverter's load output port and load

breaker(K11,K13,K15,K17,K19) ,make sure all voltage difference of each inverter are near zero. if the voltage difference is not near zero, check the wire connection between inverter load port and load breaker.

k) If all are normal, goto fourth step.

Step 4:

a) Turn on one of the load circuit breakers such as K11.

b) Check the voltage difference of same phase between breaker K13(K15,K17,K19)'s input port and output port, make sure all voltage difference of each inverter are near zero.

c) If the voltage difference is not near zero, check the connection between the load circuit breaker output port and the main load circuit breaker K1.

d) If all in-phase voltage differences are close to zero, open the load circuit breaker K13 (K15, K17, K19).

e) If all load circuit breakers are turned on, the connection check is completed. Turn off the load circuit breaker, release the round button, turn off all network circuit breakers

#### 4.3.3 ON-Grid startup parallel

a) Before the parallel operation, please ensure that all lines have been checked and correct.

b) Close the main grid circuit breaker K0, close the inverter internal grid circuit breaker (K01, K03, K05, K07, K09).

c) Check whether the grid interface voltage and frequency of each inverter are normal.

d) Close all battery circuit breakers and check whether the battery interface voltage of each inverter is normal. If it is lithium battery or SOC control mode, check whether the SOC value is displayed correctly next to the battery icon on the main interface.

e) Close all load circuit breakers (K11, K13, K15, K17, K19).

f) Press the round buttons on the side of all slaves

g) Press the round button on the side of the monster

h) After the power grid relay is closed, check whether the voltage on the load page of the main screen is normal. Click the middle inverter icon on the main screen of each device to check whether the INV Stage is 30-Working.

i) Close the total load circuit breaker for power supply, and the operation is complete.

#### 4.3.4 Off-grid startup parallel

a) Before the parallel operation, please ensure that all lines have been checked and correct.

b) Close all battery circuit breakers and check whether the battery interface voltage of each inverter

is normal. If it is lithium battery or SOC control mode, check whether the SOC value is displayed correctly next to the battery icon on the main interface.

- c) Close all load circuit breakers (K11, K13, K15, K17, K19).
- d) Press the round buttons on the side of all slaves.
- e) Press the round button on the side of the monster
- f) After the grid relay is closed, check whether the voltage on the load page of the main screen is normal. Click the middle inverter icon on the main screen of each device to check whether the INV Stage is 10-Working.
- h) Close the total load circuit breaker for power supply, and the operation is complete.

#### 4.3.4 Shut down the Inverter

- a) Turn off total load circuit breaker K1
- b) Turn off all load circuit breakers (K11, K13, K15, K17, K19).
- c) Release the round button on the side of the host
- d) Release all round buttons on the side of the slaves
- e) Turn off the grid circuit breaker K0 and all battery circuit breakers
- f) The system exits from operation.

### 4.4 Fault alarm and handling

If the device fails to start, click the Events icon on the home screen to view historical alarms and rectify faults one by one. Through the analysis of the above methods, determine the cause of the fault, and then determine the appropriate solution according to the field conditions. Table 4.2 lists the device alarm information and handling methods.

- Periodically check whether the wiring of each part of the inverter is firm and loose, especially carefully check the fan, power module, input terminal, output terminal, and grounding.
- Once the alarm stops, do not start immediately, should find out the cause and repair the restart, check should be strictly in accordance with the inverter maintenance manual prescribed steps.
- Operators must be specially trained to identify the causes of general failures and be able to troubleshoot them, such as skilfully replacing fuses, components and damaged circuit boards. Personnel without training are not allowed to operate the equipment.
- If there is an accident that is not easy to exclude or the cause of the accident is unclear, a detailed record of the accident should be made and the inverter manufacturer should be notified in time for solution.

Table 4.2 Device alarm information and handling methods

NO.	Warning	Handling Suggestions
W01	Insulation_Warning	1.Please check that the ground wire is connected correctly. 2.Seek help from us, if you cannot return to normal.
W02	Comm_LCD_Lose_Warning	1.Please Check the communication line between the LCD and the control board. 2.Seek help from us, if you cannot return to normal.
W03	LVRT_Fault_Warning	Grid voltage fluctuation,the equipment records this event.
W04	Fan_Fault_Warning	1.Please check the fan outside the enclosure for foreign objects. 2.Restart the equipment, please contact us if you still fail.
W05	PV1 low voltage warning	1.Please check the PV1 voltage range in the equipment system settings. The PV voltage setting value is between (150 ~ 500) V; 2.At present, the light is weak, and the actual photovoltaic power is low; 3.Please contact us or PV supplier again.
W06	PV2 low voltage warning	1.Please check the PV2 voltage range in the equipment system settings. The PV voltage setting value is between (150 ~ 500) V; 2.Please contact us or PV supplier again.
W07	Battery low voltage warning	1.Please check whether the battery voltage is too low; 2. Check whether the battery voltage lower limit on the battery setting page is higher than the actual battery. The minimum battery voltage setting value is between (10 ~ 55) V; 3.Check whether the maximum discharge current on the battery page exceeds the maximum battery operating current; 4.Please contact us or battery suppliers if you are alert again.
W08	ACgrid low voltage warning	1.Please check whether the grid voltage is too low; 2.Check whether the lower limit of AC voltage is too high on the AC setting page. The minimum grid voltage setting value is between (198 ~ 220) V. 3.Please contact us if you are alert again.
W09	ACgen low voltage warning	1.Please check whether the gen voltage is too low; 2.Check whether the lower limit of Gen voltage is too high on the AC setting page. The minimum gen voltage setting value is between (198 ~ 220) V. 3.Please contact us if you are alert again.
W10	AC_Volt_Unbalance_Warning	The AC voltage amplitude is unbalanced 1.Please check the AC wiring of the equipment and restart after errors; 2.If the restart failed and reported the error again, please contact us.
W11	AC_PLL_Warning	Failed to detect the output phase lock after power-on 1.Please check the AC wiring of the equipment and restart after errors; 2.If the restart failed and reported the error again, please contact us.
W12	Power_Derate_Warning	The equipment is output derated due to environmental influence records this event.
W14	Heatsink_LoTemp_Warning	Low temperature warning due to environmental influences

W15	BMS Communication Warning	<p>1.Please check whether the BMS communication cable is well connected.</p> <p>2.If you still alert, please contact us.</p>
W16	Grid voltage_Fault	<p>1.The output voltage is not within the equipment setting range, and it may be caused by the device stop.</p> <p>2.If you still alert, please contact us.</p>
W17	grid_GridPhphaseSeque_Fault	<p>1.Check the device wiring and the equipment of each power supply normally. restart the device.</p> <p>2.If you still alert, please contact us.</p>
W18	AC_Freq_Fault	<p>1.Please check the grid frequency range value in the equipment system.</p> <p>2.Please check whether the grid wiring is correct.</p> <p>3.If you still alert, please contact us.</p>
W19	gen_voltage_Fault	<p>1.The output voltage is not within the equipment setting range, and it may be caused by the device stop.</p> <p>2.If you still alert, please contact us.</p>
W20	Gen_GridPhphaseSeque_Fault	<p>1.Please check whether the gen wiring is correct.</p> <p>2.Restart the equipment, please contact us if you still fail.</p>
W21	GEN_Freq_Fault	<p>1.Please check the gen frequency range value in the equipment system.</p> <p>2.Please check whether the gen wiring is correct.</p> <p>3.If you still alert, please contact us.</p>
W23	Load low voltage warning	<p>1.Please check whether the load line wiring is correct.</p> <p>2.Please check the range of AC voltage.</p> <p>3.Restart the equipment, please contact us if you still fail.</p>
W24	PV2_VoltHigh_warning	<p>1.Please check the PV2 voltage range in the equipment system settings. The PV voltage setting value is between (150 ~ 500) V.</p> <p>2.Please contact us or PV supplier again.</p>
W25	PV1_VoltHigh_warning	<p>1.Please check the PV1 voltage range in the equipment system settings. The PV voltage setting value is between (150 ~500) V.</p> <p>2.Please contact us or PV supplier again.</p>
W26	Bat_VoltHigh_warning	<p>1.Please check whether the battery voltage is too high.</p> <p>2.Please check whether the upper limit of the battery voltage range in the equipment system is too low. The highest battery voltage setting value is between (15 ~ 60) V.</p> <p>3. Please contact us or battery suppliers if you are alert again.</p>
F01	DC Inversed Failure	<p>1.Please check whether the positive and negative batteries are reversed.</p> <p>2.If you still alert, please contact us.</p>
F02	Insulation_Failure	<p>1.Please check that the ground wire is connected correctly</p> <p>2.Seek help from us, if you cannot return to normal.</p>
F03	EEPROM_Read_Failure	Restart the equipment, please contact us if you still fail.
F04	EEPROM_Write_Failure	Restart the equipment, please contact us if you still fail.



F05	DC soft start Failure	<ol style="list-style-type: none"> <li>1.Please check whether the battery voltage is normal.</li> <li>2.Please check whether the battery voltage setting value of the device is normal The battery voltage setting value is between (15 ~ 60) V.</li> <li>3. Please contact us or battery suppliers if you are alert again.</li> </ol>
F06	Tz_Dc_OverCurr_Fault	<ol style="list-style-type: none"> <li>1.Please check the battery current limit value in the equipment system.</li> <li>2.Please check whether the PV and battery wiring of the equipment are normal.</li> <li>3.Cut off all power soure and wait for 2 minutes to discharge the inverter.Open all power circuit breakers and restart the device.</li> <li>4.If the restart failed and alarmed again, please contact us.</li> </ol>
F07	DC_OverCurr_Failure	<ol style="list-style-type: none"> <li>1.Please check the battery current limit value in the equipment system.</li> <li>2.Please check whether the PV and battery wiring of the equipment are normal.</li> <li>3. Cut off all power soure and wait for 2 minutes to discharge the inverter.Open all power circuit breakers and restart the device.</li> <li>4. If the restart failed and alarmed again, please contact us.</li> </ol>
F08	AuxPowerBoard_Failure	Restart the equipment, please contact us if you still fail.
F09	IGBT_Failure	Restart the equipment, please contact us if you still fail.
F11	AC_Main Contactor_Failure	Restart the equipment, please contact us if you still fail.
F12	AC_Slave Contactor_Failure	Restart the equipment, please contact us if you still fail.
F13	Tz_Ac_OverCurr_Fault	<ol style="list-style-type: none"> <li>1.Please check whether the backup load power is within the range.</li> <li>2.Restart and check whether it is normal.</li> <li>3.Seek help from us, if you cannot return to normal.</li> </ol>
F14	AC_OverCurr_Failure	<ol style="list-style-type: none"> <li>1.Please check whether the backup load power is within the range.</li> <li>2.Restart and check whether it is normal.</li> <li>3.Seek help from us, if you cannot return to normal.</li> </ol>
F15	GFCI_Failure	<ol style="list-style-type: none"> <li>1.Please check the wiring of the equipment and restart after errors.</li> <li>2.If the restart failed and reported the error again, please contact us.</li> </ol>
F16	Tz_COM_OC_Fault	<ol style="list-style-type: none"> <li>1.Please check whether the backup load power is within the range.</li> <li>2. Restart and check whether it is normal.</li> <li>3.Seek help from us, if you cannot return to normal.</li> </ol>
F17	BusUnbalance_Fault	Restart the equipment, please contact us if you still fail.
F18	Load_voltage_Fault	<ol style="list-style-type: none"> <li>1.Please check whether the load line wiring is correct.</li> <li>2.Please check the range of AC voltage.</li> <li>3.Restart the equipment, please contact us if you still fail.</li> </ol>
F24	Grid_Overload_Fault	<ol style="list-style-type: none"> <li>1.Please check whether the backup load power is within the range.</li> <li>2.Restart and check whether it is normal.</li> <li>3.Seek help from us, if you cannot return to normal.</li> </ol>
F25	Gen_Overload_Fault	<ol style="list-style-type: none"> <li>1.Please check whether the backup load power is within the range.</li> <li>2.Restart and check whether it is normal.</li> <li>3.Seek help from us, if you cannot return to normal.</li> </ol>

F26	DC_VoltHigh_Fault	Restart the equipment, please contact us if you still fail.
F27	DC_VoltLow_Fault	Restart the equipment, please contact us if you still fail.
F28	AC_BackFeed_Fault	Restart the equipment, please contact us if you still fail.
F29	Heatsink_HiTemp_Fault	Overhigh temperature alarm
F30	PV1 arc Failure	1.Please check the wiring of the equipment and restart after errors. 2.If the restart failed and reported the error again, please contact us.
F31	PV1 Inversed Failure	1.Please check PV1 terminal is correct. 2.If you still alert, please contact us.
F32	PV2 Inversed Failure	1.Please check PV2 terminal is correct. 2.If you still alert, please contact us.

## 4.5 Product routine maintenance suggestions



- Ensure that all the switches on the DC side and AC side of the energy storage controller, battery components, and AC power distribution cabinet are turned off.
- After the AC/DC switch of the energy storage converter is turned off, some components the energy storage controller still have residual voltage. Please wait at least 5 minutes before maintaining the energy storage converter to prevent electric shock!

### 4.5.1 Routine inspection

- Check whether the temperature of each circuit breaker of the inverter is too high during the daily peak load generally not more than 90°C .
- Check whether the ambient temperature of the inverter is too high for example, ventilate and dissipate the inverter when the temperature is too high .
- The values of inverter, box transformer voltage, current and power are compared during daily peak load.
- Daily check whether the inverter sound is normal.
- Check fault records daily to see if new faults occur.

### 4.5.2 Monthly inspection

- Check the wiring of each part of the inverter regularly every month, whether it is firm, whether it is loose, and check whether the fan, power module, and terminal block are burned or heated.
- When the inverter needs to be started and stopped, strictly follow the instructions provided by the manufacturer.
- Operators through professional training, no violations of rules and regulations.

### 4.5.3 Quarterly inspection

- Tighten the screws on the AC and DC sides of the inverter every six months.
- Dust the inverter once every three months.
- In hot weather, open the inverter room vent for ventilation and heat dissipation.

## 5 Transportation and storage

### 5.1 Product Shipping Requirements

#### 5.1.1 Logistics

- The company's inverter is delivered by a professional logistics company, and the logistics company will communicate with the dealer before delivery. Pay attention to accurately grasp the location and contact person of the delivery point, plan the delivery route, and preferably have an alternate route.
- The logistics drivers are very professional. No alcohol, drugs, or phone calls are allowed during driving. The drivers will stop to contact the distributor and consignee before arriving at the destination. Pay attention to communicating in advance, it is best not to disturb the driver halfway and distract the driving attention.
- The type of transport vehicle must be selected according to the actual road conditions. If it is too large, it may exceed the limit and cannot pass, or an unexpected situation may occur.

#### 5.1.2 Unloading and handling

- You must have a special equipment operation certificate to drive a forklift, and you must pay attention to the inspection, and remember to prohibit unlicensed operation.
- Handlers must be equipped with relevant PPE.
- If there is no delivery point for forklift unloading, the pallet can only be removed on the logistics vehicle, and 4 people cooperate to unload one set each time.

### 5.2 Product storage environment requirements

If the inverter is not put into use immediately, it must be stored as required.

- Pack the inverter in its original packaging, retain the desiccant, and seal it with tape.
- The storage temperature should be kept at  $-40^{\circ}\text{C} \sim +70^{\circ}\text{C}$ . the relative humidity should be kept at  $5\% \text{RH} \sim 95\% \text{RH}$ .
- Store in a clean and dry place, and prevent the erosion of dust and water vapor.
- Inverters with an outer packaging size of  $740*610*390$  width×height×depth can be stacked up to 4 layers. When stacking, please place the inverter carefully to avoid personal injury or equipment damage caused by the equipment falling over. Please place it upward first, and it is forbidden to invert it.
- Periodic inspection is required during storage. If insects and rats are found to bite, the packaging materials need to be replaced in time.
- After long-term storage, the inverter needs to be inspected and tested by professionals before it can be put into use.

## 6 Legal Notices

In addition to the above product warranty, national and local laws and regulations govern the power connection of the product including breach of implied terms and warranties . The company hereby declares that the terms and conditions of the product and the policy cannot and can only legally exclude all liability within a limited scope.

# 7 Attachments

## Network port definition description

MARK	J6-1	J6-2	J6-3	J6-4	J6-5	J6-6	J6-7	J6-8
Definition	NO2	COM2	NO1	COM1	CT1+	CT1-	BAT-TEMP	ISOGND2
Function	Gen adjustment control		Gen start control		External A-phase CT1 sampling input		Battery temperature sampling input	
MARK	J7-1	J7-2	J7-3	J7-4	J7-5	J7-6	J7-7	J7-8
Definition	IN1+	IN1-	IN2+	IN2-	IN3+	IN3-	RSD+	RSD-
Function	Reserve for spare						+12V output	12V GND
MARK	J14-1	J14-2	J14-3	J14-4	J14-5	J14-6	J14-7	J14-8
Definition	CANL2	CANH2	CANL2	CANH2	RS485A1	RS485B1	PV C	PV C
Function	Parallel CAN communication				Meter communication		PV control	
RJ45-	1	2	3	4	5	6	7	8
BMS	RS485B3	RS485A3	NC	CANH	CANL	NC	RS485A3	RS485B3
Function	BMS-485 communication		BMS-CAN communication			BMS-485 communication		
Parallel_A	CANH1	CANL1	SNY-01	SNY-02	ISOGND1	ISOGND1	CAN-SMH	CAN-SML
Function	Parallel synchronous communication							
Parallel_B	CANH1	CANL1	SNY-01	SNY-02	ISOGND1	ISOGND1	CAN-SMH	CAN-SML
Function	Parallel synchronous communication							
Meter_485	RS485B1	RS485A1	NC	NC	NC	NC	RS485A1	RS485B1
Function	Meter communication				Meter communication			
MODBUS	RS485B4	RS485A4	NC	RS485A2	RS485B2	NC	RS485A4	RS485B4
Function	EMS monitoring		Reserve background monitoring communications			EMS monitoring		

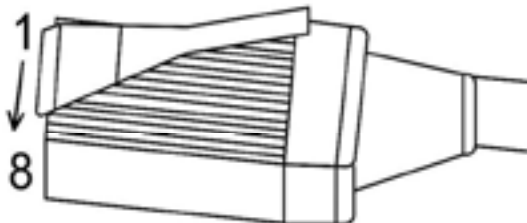
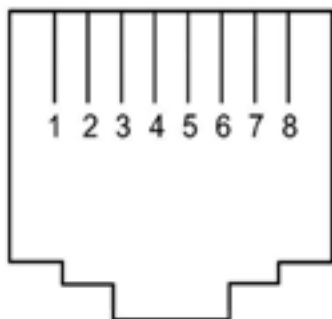

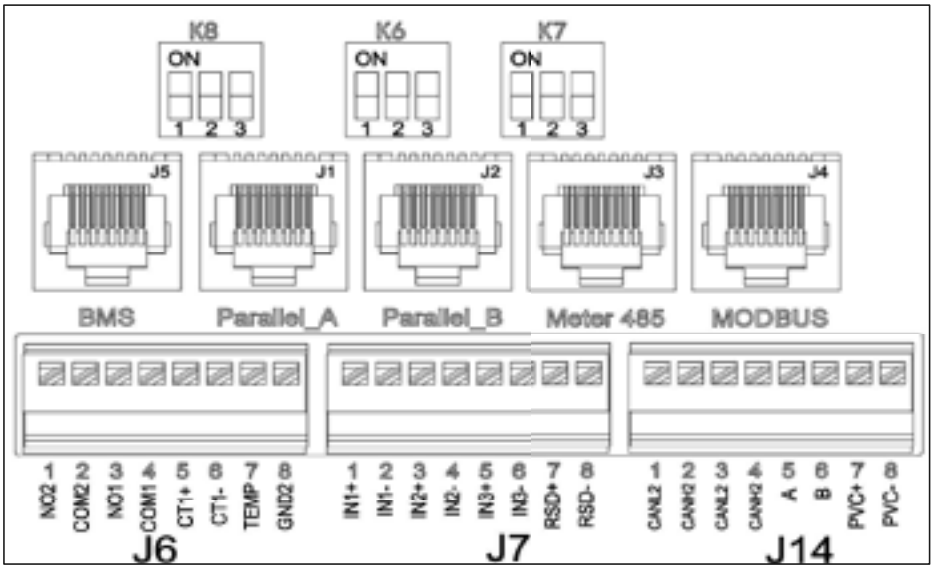

CT size and model

CTSA016 100A:50mA

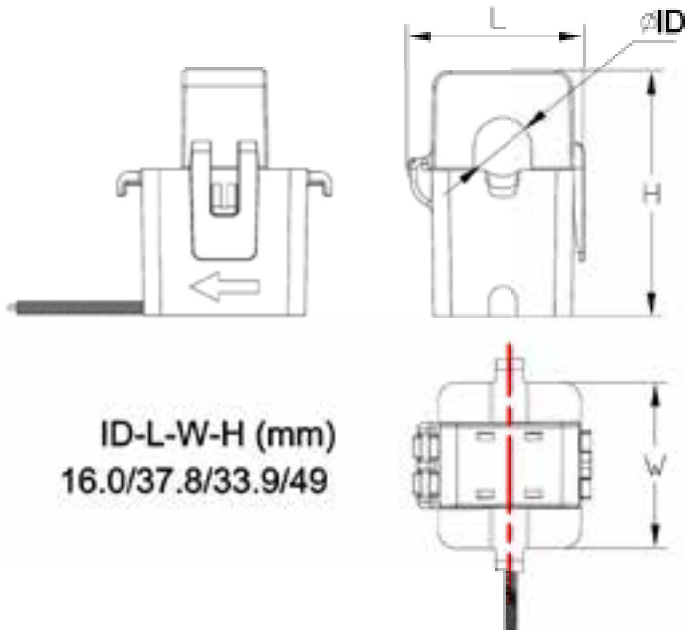

## Hybrid Inverter data

Mode	Jup-5G1-LE	Jup-6G1-LE	Jup-8G1-LE	Jup-10G1-LE
Battery Input Data				
Battery Type	Lead-acid or Li-ion			
Battery Voltage Range (V)	40-60			
Max. Charge Current (A)	120	140	190	210
Max. Discharge Current (A)	120	140	190	210
Charging Curve	3 Stages/Equalization			
External Temperature Sensor	Yes			
Charging Strategy for Li-ion Battery	Self-Adaption to BMS			
PV string Input Data				
Max. DC Input Power (W)	7,500	9,000	12,000	15,000
Vmax PV (V)	500			
MPPT Range (V)	150~425			
Start-up Voltage (V)	120			
PV Input Current (A)	17+17	17+17	26+26	26+26
Max. PV ISC (A)	20+20	20+20	34+34	34+34
No. of MPPT Trackers	2	2	2	2
No. of String Per MPPT Tracker	1+1	1+1	2+2	2+2
AC Output Data				
Rated AC Output Power and UPS Power (W)	5,000	6,000	8,000	10,000
Max. AC Output Power (VA)	6,000	7,200	9,600	12,000
Peak Power (off grid)	2 times of rated power, 10s			1.8 times of rated power, 10s
AC Output Rated Current (A)	22.7/21.7	27.3/26.1	34.5/33	45.5/43.5
Max. AC Current (A)	25/23.9	30/28.7	40/38.3	50.0/47.8
Max. Continuous AC Passthrough (A)	40	40	50	60
Power Factor	0.8 leading to 0.8 lagging			
Output Frequency and Voltage	50/60Hz, 220/230Vac(single phase)			
Grid Type	Single phase			
Current Harmonic Distortion	THD<3%(Linear load <1.5%)			
Efficiency				
Max. Efficiency	97.9%			
Euro Efficiency	96.9%			
MPPT Efficiency	99.9%			
Protection				
Integrated	PV Input Lightning Protection, Anti-islanding Protection, PV String Input Reverse Polarity Protection, Insulation Resistor Detection, Residual Current Monitoring Unit, Output Over Current Protection, Output Shorted Protection			
PV ARC Fault Detection	Optional			
Output Over Voltage Protection	DC Type II/AC Type III			
Certification and standards				
Grid Regulation	CEI 0-21,VDE-AR-N 4105,NRS 097,IEC61727,G99,G98,VDE 0126-1-1,RD 1699,C10-11			



EMC/Safety Regulation	IEC/EN 62109-1 IEC/EN 62109-2,IEC/EN 61000-6-1,IEC/EN 61000-6-2, IEC/EN 61000-6-3, IEC/EN 61000-6-4
General Data	
Operating Temperature Range(°C) Cooling	-45~60, 45 Derating
Cooling	Smart cooling
Noise(dB)	≤45
Communication with BMSC	CAN, RS485
Weight (kg)	35
Dimensions (mm)	514W×665H×292D
Protection Degree	IP65
Installation Style	Wall-mounted
Warranty	5 Years
Max operation altitude	2000m
Relative humidity	0~100%(Non-condensation)

Version No.1.3